

Directional control valve, pilot-operated, with integrated digital axis controller (IAC-Multi-Ethernet)

Type 4WRLD



H8073

- ▶ Sizes 10 ... 35
- ▶ Component series 4X
- ▶ Maximum operating pressure 350 bar
- ▶ Rated flow 60 ... 1500 l/min ($\Delta p = 10$ bar)



Features

- ▶ Open
 - Integrated digital axis control functionality (IAC-Multi-Ethernet)
 - Bus connection/service interface (Sercos, EtherCAT, EtherNet/IP, PROFINET RT, POWERLINK, VARAN)
- ▶ Scalable
 - 2 configurable analog sensor inputs
 - 1 input for linear position measurement system (SSI, 1Vpp or EnDat 2.2)
- ▶ Precise
 - Best-in-class hydraulic controller
 - High response sensitivity and low hysteresis
- ▶ Safe
 - Internal safety function (can be used up to category 4/PL e according to EN 13849-1)
 - CE conformity according to EMC Directive 2014/30/EU

Contents

Features	1
Ordering code	2, 3
Symbols	4
Function	5, 6
Pilot oil supply	7, 8
Technical data	9 ... 13
Electrical connections, assignment	14, 15
Block diagram/controller function block	16
LED displays	17
Characteristic curves	18 ... 35
Dimensions	36 ... 41
Accessories	42, 43
Representation of the axis controller in the system network	43
Project planning information	44
Further information	44

Ordering code

01	02	03	04	05	06	07	08	09	10	11	12	13	14	15	16
4	WRL	D						-	4X	/		/	24	D6	*

01	4 main ports	4
02	Directional control valve, pilot-operated	WRL
03	With integrated digital axis controller	D
04	Size 10	10
	Size 16	16
	Size 25	25
	Size 27	27
	Size 35	35
05	Symbols; possible version see page 4	

Nominal flow ($\Delta p = 5$ bar per control edge)

06	- Size 10		
	60 l/min (only symbol E, E1-, W6-, W8-, V and V1-)	60	
	100 l/min	100	◇
	- Size 16		
	200 l/min (only symbol W6- and W8-)	200	◇
	250 l/min (only symbol E, E1-, V, V1- and Q3)	250	◇
	- Size 25		
	350 l/min (only symbol W6- and W8-) ¹⁾	350	◇
	400 l/min (only symbol E, E1-, V, V1- and Q3)	400	◇
	- Size 27		
	430 l/min (only symbol W6- and W8-) ¹⁾	430	◇
	600 l/min (only symbol E, E1-, V, V1- and Q3)	600	◇
	- Size 35		
	1000 l/min (only symbol E, E1-, V and V1-)	1000	
	1200 l/min (only symbol W6- and W8-) ¹⁾	1200	◇
1500 l/min (only symbol E, E1-, V, V1- and Q3-)	1500	◇	

Flow characteristic

07	Linear	L	◇
	Linear with fine control range (only NG10; other sizes on request)	P	
	Progressive with linear fine control range (only symbols Q3-)	M	
08	Without overlap jump (only symbols V, V1- and Q3)	no code	
	With overlap jump (opening point 5% with covered valve; only symbols E, E1-, W6-, W8-)	J	
09	Component series 40 ... 49 (40 ... 49: Unchanged installation and mounting dimensions)	4X	

Seal material (observe compatibility of seals with hydraulic fluid used, see page 11)

10	NBR seals	M	◇
	FKM seals	V	

Pilot oil flow

11	External pilot oil supply, external pilot oil return	XY	◇
	Internal pilot oil supply, external pilot oil return	PY	
	Internal pilot oil supply; internal pilot oil return	PT	◇
	External pilot oil supply, internal pilot oil return	XT	

Ordering code

01	02	03	04	05	06	07	08	09	10	11	12	13	14	15	16
4	WRL	D						- 4X	/		/	24	D6		*

12	Supply voltage 24 V	24
----	---------------------	-----------

Ethernet interface

13	EtherNET/IP	E
	PROFINET RT	N
	Sercos	S
	EtherCAT (CANopen profile)	T
	POWERLINK (CANopen profile)	W
	VARAN	V

Electrical interface

14	±10 VDC or 4 ... 20 mA	D6
----	------------------------	-----------

Sensor interfaces

15	0 ... 10 V / 4 ... 20 mA / EnDat 2.2	S	
	0 ... 10 V / 4 ... 20 mA / SSI	T	◇
	0 ... 10 V / 4 ... 20 mA / 1Vpp	U	◇
16	Further details in the plain text	*	

1) Higher rated flow upon request

 **Notice:** ◇ = Preferred type

Symbols

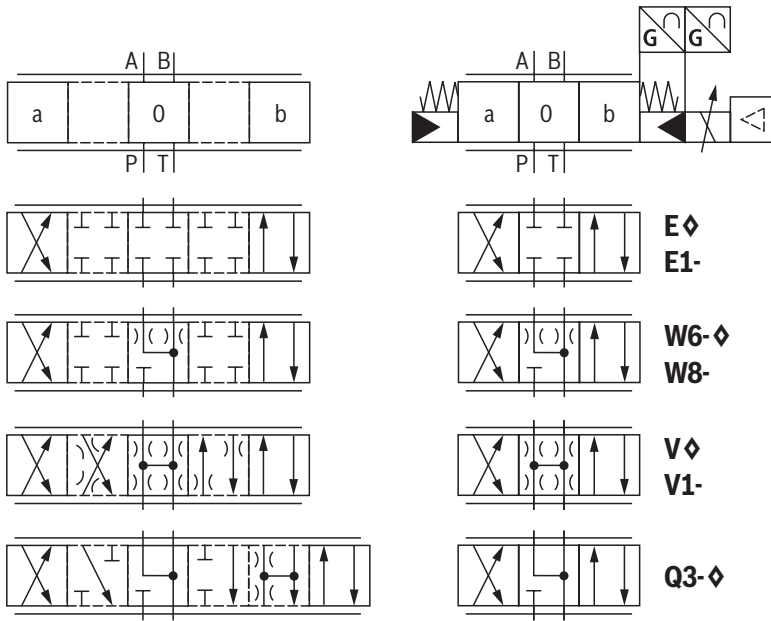

With symbol E1-, V1- and W8-:

$P \rightarrow A: q_{V \max}$ $B \rightarrow T: q_{V/2}$
 $P \rightarrow B: q_{V/2}$ $A \rightarrow T: q_{V \max}$

Notice: ◇ = Preferred type

Version	Simple	Detailed
"XY"		
"PY"		
"PT"		
"XT"		

Notice:

- Representation dimensions according to ISO 1219-1. Hydraulic interim positions are shown by dashes.
- For information on the "switch-off behavior", refer to Technical data on page 11.
- Symbols V and V1- are not suitable for use in safety applications (no overlap).

Function

General

The pilot-operated **IAC-Multi-Ethernet** valve (Integrated **A**xis **C**ontroller based on directional control valves) is a digital directional control valve with integrated axis controller and the following functionalities:

- ▶ Position control
- ▶ Pressure/force control
- ▶ Closed-loop speed control
- ▶ Alternating control (position - pressure/force)
- ▶ Alternating control (flow - pressure/force)
- ▶ pQ function (flow-controlled)

Among others, the following operating modes are possible:

- ▶ Valve direct control
- ▶ Drive-controlled position control
- ▶ Drive-controlled positioning
- ▶ Positioning block operation
- ▶ The command values are preset via the Ethernet interface (X7E1 or X7E2) or, alternatively, via the analog/digital interface (XH2)
- ▶ The feedback information of the actual value signals to the higher-level control is provided optionally either via the Ethernet interface (X7E1 or X7E2) or the analog/digital interface (XH2)
- ▶ The controller parameters are set via the Ethernet interface (X7E1 or X7E2)

Set-up

The directional control valve with IAC-Multi-Ethernet electronics mainly consists of:

- ▶ Pilot control valve (1) with control spool and sleeve in servo quality
- ▶ Main stage (2) with centering springs and position feedback
- ▶ Integrated digital axis controller (3) with:
 - analog/digital interface (XH2)
 - Ethernet interfaces (X7E1, X7E2)
 - analog sensor interfaces (X2M1, X2M2)
 - digital sensor interface (X8M)
 - interface for the position transducer of the main stage (X8A)

Function

The integrated electronics (OBE) compare the specified command value to the position actual value of the control spool of the main stage. In case of a control deviation, the control solenoid of the pilot control valve is activated and its control spool is adjusted.

The flow which is activated via the control cross-sections at the pilot control valve leads to an adjustment of the control spool of the main valve. The stroke/control cross-section of the main valve is regulated proportionally to the command value. In case of a command value presetting of 0%, the electronics adjust the control spool of the main valve to central position.

The pilot oil supply in the pilot control valve is either internal via port P or external via port X. The feedback can be internal via port T or external via port Y to the tank.

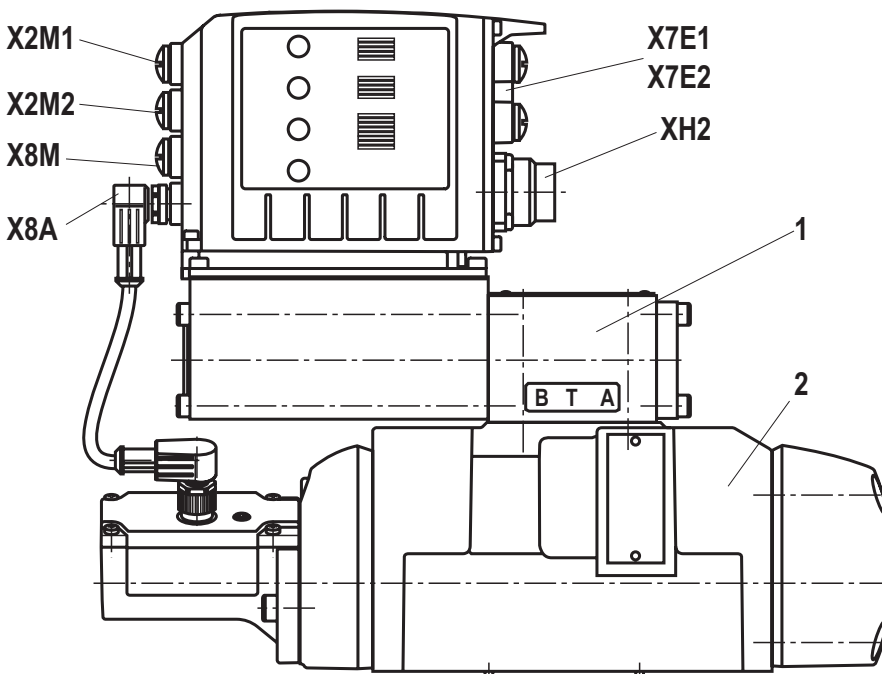

Function

Symbol V and V1-

The control spool of the main valve is not in a safe position after the release is switched off. The enable acknowledgment (pin 3) is not set.

If the supply voltage fails or in case of cable break, the integrated electronics will de-energize the control solenoid, the pilot control spool will move to the fail-safe position and will unload the pilot oil chambers of the main valve. Operated by the spring, the main valve control spool will move to the offset position (approx. 6% P → B/A → T).

Symbol E., W. and Q3-

If the control spool of the main valve is in the covered spring-centered central position, the enable acknowledgment (pin 3) is set. If the control spool of the main valve leaves the covered spring-centered central position or the release is set, the enable acknowledgment expires.

If the supply voltage fails or in case of cable break, the integrated electronics will de-energize the control solenoid, the pilot control spool will move to the fail-safe position and will unload the pilot oil chambers of the main valve. The main valve control spool assumes the covered, spring-centered central position.

Safety function

Thanks to the control solenoids (enable pin 3, low signal) at the connector (XH2), shut-off is enabled.

The control spool of the valve is in spring-centered central position after shut-off (see notes).

Enable acknowledgment pin 8 for solenoid B is "high". When the control solenoid is connected (enable pin 3, high signal), the valve can be regulated in both directions by command value presetting.

Enable acknowledgment pin 8 for solenoid B is "low". The integrated control electronics (OBE) of the valve enables the additional shut-off of a channel according to EN 13849-1 in both directions (depending on the symbol, the valve can be considered as safely shut-off). For this purpose, a suitable control system must be provided to perform the plausibility check between the direction-dependent valve signals "enable input" and "enable acknowledgment" (diagnosis signal fed back by the valve) and to react in an error case. When using symbol V, the valve cannot be used in a safety-relevant manner according to EN 13849-1.

Monitoring

The digital control electronics enable comprehensive monitoring functions/error detection including:

- ▶ Undervoltage
- ▶ Communication error
- ▶ Cable break for analog sensor inputs and digital position measurement system

- ▶ Short-circuit monitoring for analog/digital outputs
- ▶ Monitoring of the microcontroller (watchdog)
- ▶ Temperature of the integrated electronics

IndraWorks DS PC program

To implement the project planning task and to parameterize the IAC-Multi-Ethernet valves, the user may use the IndraWorks DS engineering tool (see accessories):

- ▶ Project planning
- ▶ Parameterization
- ▶ Commissioning
- ▶ Diagnosis
- ▶ Comfortable administration of all data on a PC
- ▶ PC operating systems: Windows XP (SP3), Windows 7-10

Notice:

- ▶ Symbol V and V1-: Pilot-operated 4/3 directional control valves are only functional in the active control loop and do not have a locking basic position when deactivated. Consequently, "external check valves" are required in many applications and must be taken into account regarding the switch-on/switch-off order. While the electrical supply voltage is being switched off, the drive may be accelerated for a short time in functional direction P → B.
- ▶ Symbol E. and W.: Pilot-operated 4/3 directional control valves with positive overlap are functional in controlled or regulated axes. The overlap in the de-energized state is approx. 20% of the control spool stroke. While the release is being switched off, the drive may be accelerated for a short time in functional direction P → B. (For further details, please refer to operating instructions 29391-B)
- ▶ 4/3 directional control valves do not have a leakage-free basic locking when deactivated. Leakage must be considered when designing the drive.
- ▶ Valve type 4WRLD can be used as shut-off element of cat. 3 or 4 (up to PL e according to EN 13849-1). For both categories, an additional shut-off element is required to achieve a two-channel shut-off. For further information on the safety application, see operating instructions 29391-B.

Pilot oil supply (schematic illustration)

NG10

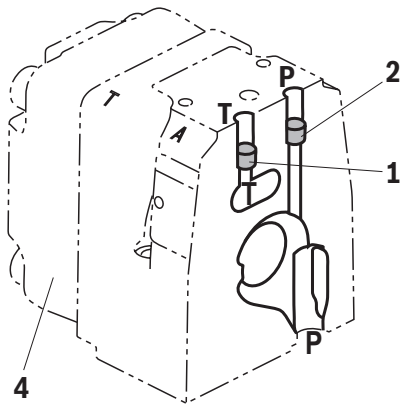

NG16

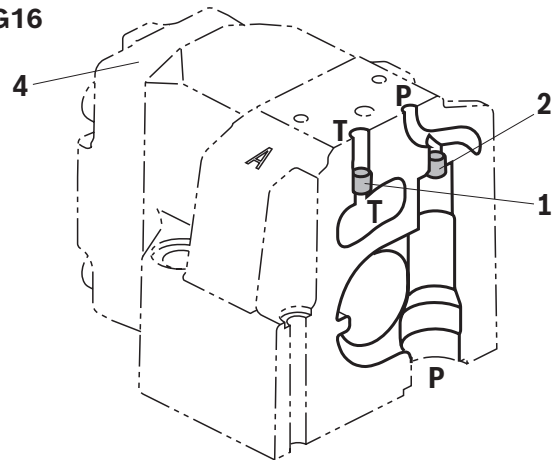

NG25

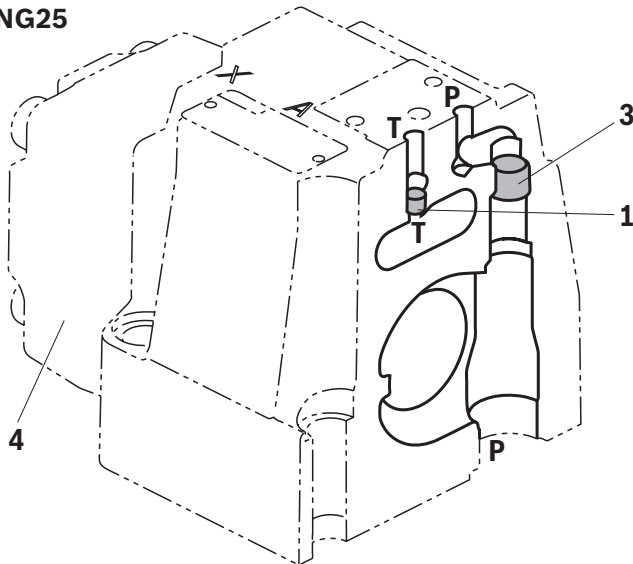

NG27

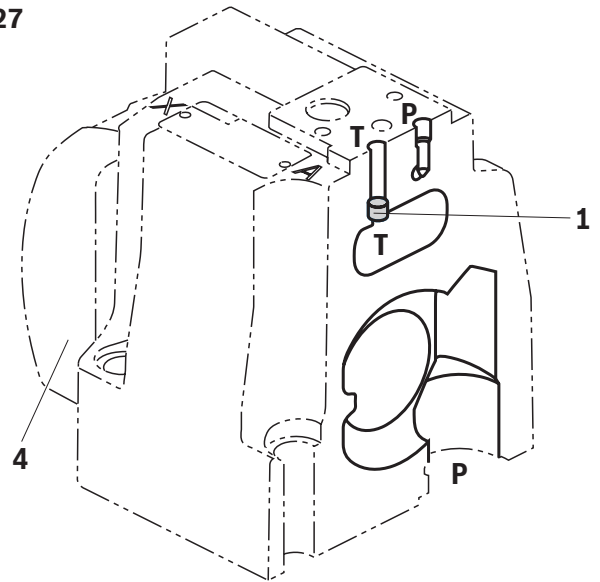

NG35

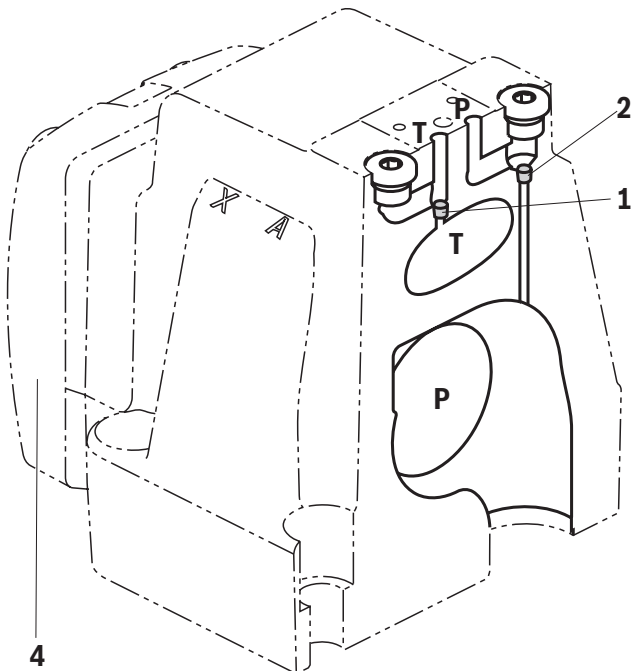

- 1 Plug screw M6 according to DIN 906, SW3
– pilot oil return
- 2 Plug screw M6 according to DIN 906, SW3
– pilot oil supply
- 3 Plug screw M12 x 1.5 according to DIN 906, SW6
– pilot oil supply
- 4 Housing cover main stage (position transducer side)

Pilot oil supply

external: **2, 3** closed
internal: **2, 3** open

Pilot oil return

external: **1** closed
internal: **1** open

Further explanations on page 8.

Pilot oil supply

Version "XY"

External pilot oil supply

External pilot oil return

In this version, the pilot oil is supplied from a separate control circuit (external).

The pilot oil return is not directed into channel T of the main valve but is separately directed to the tank via port Y (external).

Version "PY"

Internal pilot oil supply

External pilot oil return

With this version, the pilot oil is supplied from channel P of the main valve (internal).

The pilot oil return is not directed into channel T of the main valve but is separately directed to the tank via port Y (external).

In the subplate, port X is to be closed.

Version "PT"

Internal pilot oil supply

Internal pilot oil return

With this version, the pilot oil is supplied from channel P of the main valve (internal).

The pilot oil is directly returned to channel T of the main valve (internal).

In the subplate, ports X and Y are to be closed.

Version "XT"

External pilot oil supply

Internal pilot oil return

In this version, the pilot oil is supplied from a separate control circuit (external).

The pilot oil is directly returned to channel T of the main valve (internal).

In the subplate, port Y is to be closed.



Notice:

The modification of the pilot oil supply may only be performed by authorized specialists or at the factory. The maximum admissible operating parameters must be observed, see page 10.

Technical data

(For applications outside these values, please consult us!)

General						
Size	NG	10	16	25	27	35
Type of connection	Subplate mounting					
Porting pattern		ISO 4401-05-05-0-05	ISO 4401-07-07-0-05	ISO 4401-08-08-0-05	ISO 4401-08-08-0-05	ISO 4401-10-09-0-05
Weight	kg	9	12	19	21	80
Installation position	Any					
Ambient temperature range	°C	-20 ... +60				
Storage temperature range	°C	+5 ... +40				
Maximum storage time	Years	1 (if the storage conditions are observed, refer to the operating instructions 07600-B)				
Maximum relative humidity (no condensation)	%	95				
Protection class according to EN 60529	IP65 (if suitable and correctly mounted mating connectors are used)					
Maximum surface temperature	°C	120 (individual operation)				
MTTF _D value according to EN ISO 13849	▶ Hydraulic (category 1)	Years	75 (for further details, see operating instructions 29391-B)			
	▶ Hydraulic and electric (category 3 and 4, without power supply unit)	Years	70 (for further details, see operating instructions 29391-B)			
Can be used up to category according to EN ISO 13849-1	3; 4 (to PL e); as a switch-off element					
Sine test according to DIN EN 60068-2-6	10 ... 2000 Hz / maximum of 10 g / 10 cycles / 3 axes					
Noise test according to DIN EN 60068-2-64	20 ... 2000 Hz / 10 g _{RMS} / 30 g peak / 30 min. / 3 axes					
Transport shock according to DIN EN 60068-2-27	15 g / 11 ms / 3 axes					
Conformity	▶ CE according to EMC directive 2014/30/EU, tested according to		EN 61000-6-2 and EN 61000-6-3			
	▶ RoHS directive		2011/65/EU ¹⁾			

¹⁾ The product fulfills the substance requirements of the RoHS directive 2011/65/EU.

Technical data

(For applications outside these values, please consult us!)

Hydraulic							
Size	NG	10	16	25	27	35	
Maximum operating pressure	▶ Ports A, B, P						
	– External pilot oil supply	bar	350		270	350	
	– Internal pilot oil supply	bar	280		270	280	
	▶ Port X	bar	280		270	280	
	▶ Port T ³⁾						
	– External pilot oil return	bar	250		210	350	
	– Internal pilot oil return	bar	250		210	250	
▶ Port Y	bar	250		210	250		
Hydraulic fluid		See table page 11					
Hydraulic fluid temperature range (flown-through)	°C	–20 ... +70					
Viscosity range	▶ Recommended	mm ² /s	20 ... 100				
	▶ Maximum	mm ² /s	10 ... 800				
Maximum admissible degree of contamination of the hydraulic fluid; cleanliness class according to ISO 4406 (c)		Class 18/16/13 ²⁾					
Rated flow ($\Delta p = 5$ bar per control edge) ^{3); 4)}	l/min	60/100	200/250	350/400	430/600	1000/1200/ 1500	
Maximum flow	l/min	300	800	1250	1850	4700	
Maximum leakage flow (inlet pressure 100 bar)	▶ Symbol E, E1-						
	– Main valve	l/min	0.10	0.17	0.19	0.83	
	– Main valve + pilot control valve	l/min	0.16	0.28	0.36	1.11	
	▶ Symbol W6-, W8-						
	– Main valve	l/min	0.21	0.35	0.38	1.67	
	– Main valve + pilot control valve	l/min	0.26	0.45	0.56	1.95	
Maximum zero flow (inlet pressure 100 bar)	▶ Symbol V, V1-						
	– Main valve	l/min	1.7	2.3	2.8	3.3	7.2
	– Main valve + pilot control valve	l/min	1.85	2.6	3.2	3.7	7.65
	▶ Symbol Q3-						
	– Main valve	l/min	0.4	1.6	1.8	2.2	1.6
	– Main valve + pilot control valve	l/min	0.55	1.9	2.2	2.6	2.05
Minimum pilot pressure (pilot control valve)	bar	10					
Pilot flow ⁵⁾	▶ Symbol E, W	l/min	3	4	10	26	
	▶ Symbol V, Q3-	l/min	4	11	19	29	

²⁾ The cleanliness classes specified for the components must be adhered to in hydraulic systems. Effective filtration prevents faults and at the same time increases the life cycle of the components.

³⁾ Flow for deviating Δp (per control edge):

$$q_x = q_{Vnom} \times \sqrt{\frac{\Delta p_x}{5}}$$

⁴⁾ Observe project planning information, see page 44

⁵⁾ At port X and Y with stepped input signal from 0 ... 100% (100 bar)

Technical data

(For applications outside these values, please consult us!)

Hydraulic fluid	Classification	Suitable sealing materials	Standards	Data sheet
Mineral oils	HL, HLP	NBR, FKM	DIN 51524	90220
Bio-degradable	▶ Insoluble in water	HETG	ISO 15380	90221
		HEES		
	▶ Soluble in water	HEPG	ISO 15380	
Flame-resistant	▶ Water-free	HFDU (glycol base)	ISO 12922	90222
		HFDU (ester base)		
		HFDR		
	▶ Containing water	HFC (Fuchs: Hydrotherm 46M, Renosafe 500; Petrofer: Ultra Safe 620; Houghton: Safe 620; Union: Carbide HP5046)	NBR	ISO 12922



Important information on hydraulic fluids:

- ▶ For further information and data on the use of other hydraulic fluids, please refer to the data sheets above or contact us.
- ▶ There may be limitations regarding the technical valve data (temperature, pressure range, life cycle, maintenance intervals, etc.).
- ▶ The ignition temperature of the hydraulic fluid used must be 50 K higher than the maximum surface temperature.
- ▶ **Bio-degradable and flame-resistant – containing water:**
If components with galvanic zinc coating (e.g., version "J3" or "J5") or parts containing zinc are used, small amounts of dissolved zinc may get into the hydraulic system and cause accelerated aging of the hydraulic fluid. Zinc soap may form as a chemical reaction product, which may clog filters, nozzles and solenoid valves – particularly in connection with local heat input.

▶ Flame-resistant – containing water:

- Due to the increased cavitation tendency with HFC hydraulic fluids, the life cycle of the component may be reduced by up to 30% as compared to the use with mineral oil HLP. In order to reduce the cavitation effect, it is recommended – if possible specific to the installation – backing up the return flow pressure in ports T to approx. 20% of the pressure differential at the component.
- Dependent on the hydraulic fluid used, the maximum ambient and hydraulic fluid temperature must not exceed 50 °C. In order to reduce the heat input into the component, the command value profile is to be adjusted for proportional and high-response valves.

Static/dynamic						
Size	NG	10	16	25	27	35
Hysteresis	%	<0.1				
Range of inversion	%	<0.08				
Response sensitivity	%	<0.05				
Manufacturing tolerance q_{Vmax}	%	≤10				
Temperature drift (temperature range 20 ... 80 °C)	%/10 °C	Zero shift <0.25				
Zero point calibration	%	±1 (ex works)				
Step response time for 0 ... 100% at X = 210 bar)	ms	40	60	60	60	90
Switch-off behavior (after electrical shut-off)	▶ Symbol E, E1-	Pilot control valve in fail-safe position, main valve moves to overlapped spring-centered central position				
	▶ Symbol W6-, W8-	Pilot control valve in "fail-safe" position, main valve moves to spring-centered central position (P blocked, A/B to port T open).				
	▶ Symbol V, V1-	Pilot control valve in fail-safe position, main valve moves to spring-centered "offset position" (approx. 6%, P→B/A→T)				
	▶ Symbol Q3	Pilot control valve in "fail-safe" position, main valve moves to spring-centered "offset position" (P blocked, A/B to port T open)				

Technical data

(For applications outside these values, please consult us!)

Electrical, integrated electronics (OBE)				
Supply voltage ^{6; 7)}	▶ Nominal value	VDC	24	
	▶ Minimum	VDC	18	
	▶ Maximum	VDC	36	
	▶ Maximum residual ripple	V _{pp}	2.5 (comply with the absolute supply voltage limit values)	
	▶ Maximum power consumption	W	40	
	▶ Fuse protection, external	A	4, time-lag	
	Current consumption	▶ Maximum ⁸⁾	A	2.5
▶ Impulse current		A	4	
Relative duty cycle time according to VDE 0580			S1 (continuous operation)	
Functional ground and screening			See pin assignment page 14 and 15	
Booting time		s	<15	
Digital inputs (enable) XH2	▶ Quantity	Optionally up to 2, configurable (analog inputs are omitted)		
	▶ Low level range	V	-3 ... 5	
	▶ High-level range	V	>15	
	▶ Maximum current consumption at high level	mA	<1	
Digital outputs (enable acknowledgment) XH2	▶ Quantity	1		
	▶ Low level range	V	0 ... 3	
	▶ High-level range	V	>15	
	▶ Current carrying capacity	A	1.5 (short-circuit-proof)	
	▶ Inductive load admissible	No		
Analog inputs (command value) XH2	▶ Number (current and voltage input parameterizable)	Optionally up to 2, configurable (digital inputs are no longer required)		
	▶ Voltage inputs (differential inputs)			
	- Measurement range	V	-10 ... +10	
	- Input resistance	kΩ	80 +10%	
	▶ Current inputs (reference to AGND)			
	- Input current range	4 ... 20 (0 ... 20 physically)		
	- Input resistance	Ω	200, measuring resistance plus FET	
Analog outputs (actual value) XH2	▶ Number (current and voltage input parameterizable)	1		
	▶ Voltage outputs			
	- Output range	V	-10 ... +10 (0 ... 10 by software)	
	- Minimum load impedance	kΩ	10	
	▶ Current outputs			
	- Output range	mA	0 ... 20 (4 ... 20 by software)	
	- Maximum load	Ω	200	

⁶⁾ Supply voltage is used directly for sensor connections X2M1, X2M2 and X8M (no internal voltage limitation)

⁷⁾ Voltage limit values must be observed directly at the connector of the valve (observe line length and cable cross-section!)

⁸⁾ The maximum current consumption will increase when using the sensor inputs or the switching output according to the external load

Technical data

(For applications outside these values, please consult us!)

Analog sensors X2M1, X2M2	▶ Number (current and voltage input configurable)		1 per connector	
	▶ Supply voltage	V	24 (corresponding to supply voltage applied to XH2)	
	▶ Maximum supply current	mA	350 (sum X2M1, X2M2 and X8M)	
	▶ Voltage inputs			
	– Measurement range	V	0 ... 10	
	– Input resistance	kΩ	80 +10%	
	▶ Current inputs (reference to AGND)			
	– Input current range		4 ... 20 (0 ... 20 physically)	
	– Input resistance	Ω	200, measuring resistance plus PTC	
	Digital sensor X8M	▶ Supply voltage		24 V or 5 V
▶ Maximum supply current		– 24 V	mA	350 (sum X2M1, X2M2 and X8M)
		– 5 V	mA	250
▶ SSI transducer				
– Coding				Gray
– Data width		Bit		12 ... 28
– Transfer frequency range				80 kHz ... 1 MHz
– Line receiver / driver				RS485
▶ Endat encoder				
– Line receiver / driver				RS485
– Resolution				Minimum 10 nm and multiple
– Version				2.2
▶ 1Vpp-encoder				
– Maximum transmission frequency	kHz		250	

Electrical connections, assignment

Connector pin assignment "XH2", 11-pole + PE according to EN 175201-804

Pin	Core marking		Interface assignment "D6"
	Cable, one-part ¹⁾	Cable, split ²⁾	
1	1	1	Supply voltage
2	2	2	GND
3	3	white	Enable input
4	4	yellow	Command value 1 ³⁾
5	5	green	Reference potential command values
6	6	violet	
7	7	pink	Command value 2 ³⁾
8	8	red	Enable acknowledgment ⁵⁾
9	9	brown	Signal must not be evaluated
10	10	black	No function
11	11	blue	Switching output 24 V – fault-free operation (supply voltage -1 V / error (0 V) or power circuit signal)
PE	green-yellow	green-yellow	

1) Core marking of the connection lines for mating connector with cable set (see accessories, page 42, material numbers R901268000, R901272854, R901272852)

2) Core marking of the connection lines for mating connector with cable set (see accessories, page 42, material numbers R900884671, R900032356, R900860399)

3) Selection via commissioning software

4) For diagnostic purposes, precise actual value response via Ethernet interface

5) A load increases the current consumption on pin 1

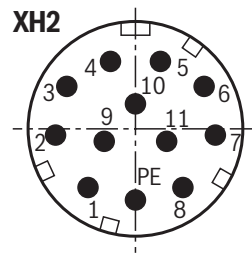

Connector pin assignment for Ethernet interface "X7E1" and "X7E2" (coding D), M12, 4-pole, socket

Pin	Assignment
1	TxD +
2	RxD +
3	TxD -
4	RxD -
5	Not used

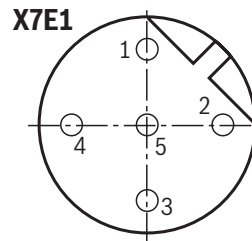

Analog configurable sensor interfaces, connections "X2M1", "X2M2" (coding A), M12, 5-pole, socket

Pin	Assignment
1	Voltage output (sensor supply) ^{1); 2)}
2	Sensor signal input current ³⁾
3	GND
4	Sensor signal input voltage ³⁾
5	Negative differential amplifier input to pin 4 (optional)

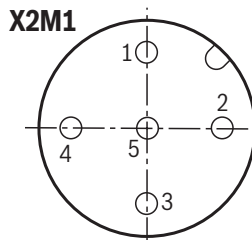

1) Voltage output same as voltage supply connected to input XH2. (Maximum load capacity see page 15)

2) A load increases the current consumption of the valve (pin 1 on the connector XH2)

3) Only one signal input per interface, configurable

Electrical connections, assignment

Digital sensor interface SSI, EnDat 2.2 or 1Vpp measurement system "X8M", M12, 8-pole, socket

Pin	Assignment		
	SSI ¹⁾	EnDat 2.2 ^{1; 2)}	1Vpp
1	GND	GND	GND
2	+24 V ³⁾	+5 V ³⁾	+5 V ³⁾
3	Data +	Data +	A +
4	Data -	Data -	A -
5	GND	GND	B +
6	Clock -	Clock -	B -
7	Clock +	Clock +	R +
8	+24 V ³⁾	+5 V ³⁾	R -

1) Pins 2, 8 and 1, 5 have the same assignment each

2) Supported resolution ≥ 10 nm

3) A load increases the current consumption of the valve (pin 1 on the connector XH2)

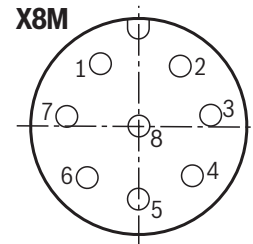

Notice:

- ▶ Reference potential for all signals: GND
- ▶ The shield must be placed on both sides of the metal housing of the plug-in connectors.
- ▶ For a cable length >30 m, an external overvoltage arrester must be provided in the valve voltage supply.

Block diagram/controller function block

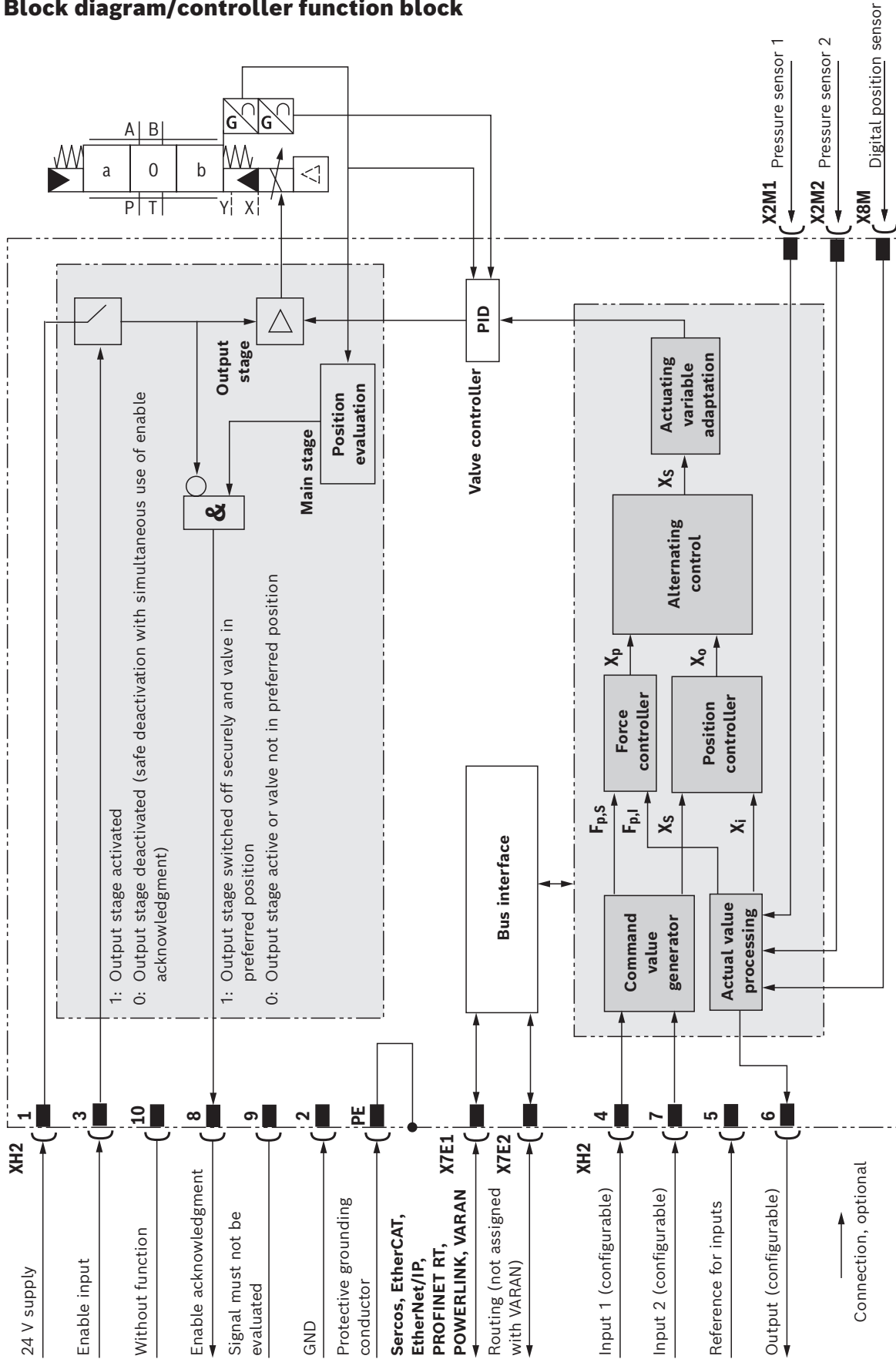

LED displays

LED	Interface	Sercos	EtherNET/IP	EtherCAT	PROFINET RT	POWERLINK	VARAN
1	X7E1	Activity	Activity	Not used	Activity	Not used	Active
2		Link	Link	Link/activity	Link	Link/data activity	Link
3	Electronics module	S	Network status	Network status	Network status	Status/error	Network status
4		Module status	Module status	Module status	Module status	Module status	Module status
5	X7E2	Activity	Activity	Not used	Activity	Not used	not used
6		Link	Link	Link/activity	Link	Link/data activity	not used

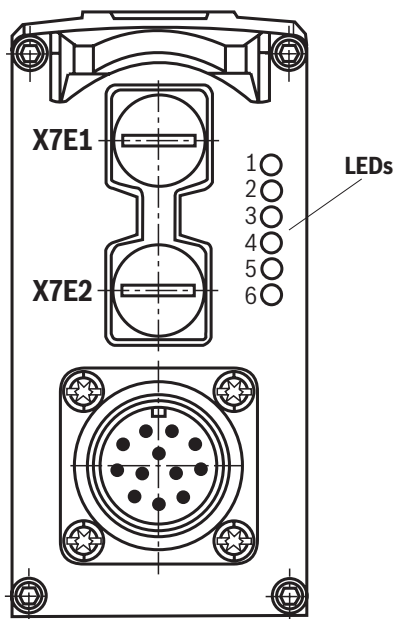

Meaning of the status LEDs

Module status LED (LED 4)	Display status
Off	No voltage supply
Green-red, flashing	Initialization
Green, flashing	Drive ready for operation
Green	Drive active
Orange, flashing	Warning
Red, flashing	Error

Network status LED (LED 3)	Display status
Off	No voltage supply
Green	Operation

Activity LED (LED 1 and 5)	Display status
Flashing	Data sent/received

Link LED and Activity LED (LED 2 and 6)	Display status
Permanently lit	Cable plugged in, connection established

Notice:

- ▶ LEDs 1, 2, 5 and 6 relate to interfaces "X7E1" and "X7E2"
- ▶ Module status LEDs 3 and 4 relate to the electronics module
- ▶ For a detailed description of the diagnosis LEDs, please refer to the functional description "Rexroth HydraulicDrive HDx".
- ▶ Function is only available after start-up of the electronics.

Characteristic curves: Flow characteristic "L"
 (valid for HLP46, $\vartheta_{oil} = 40 \pm 5 \text{ } ^\circ\text{C}$; $\Delta p = 5 \text{ bar}$ per control edge)

Flow/signal function

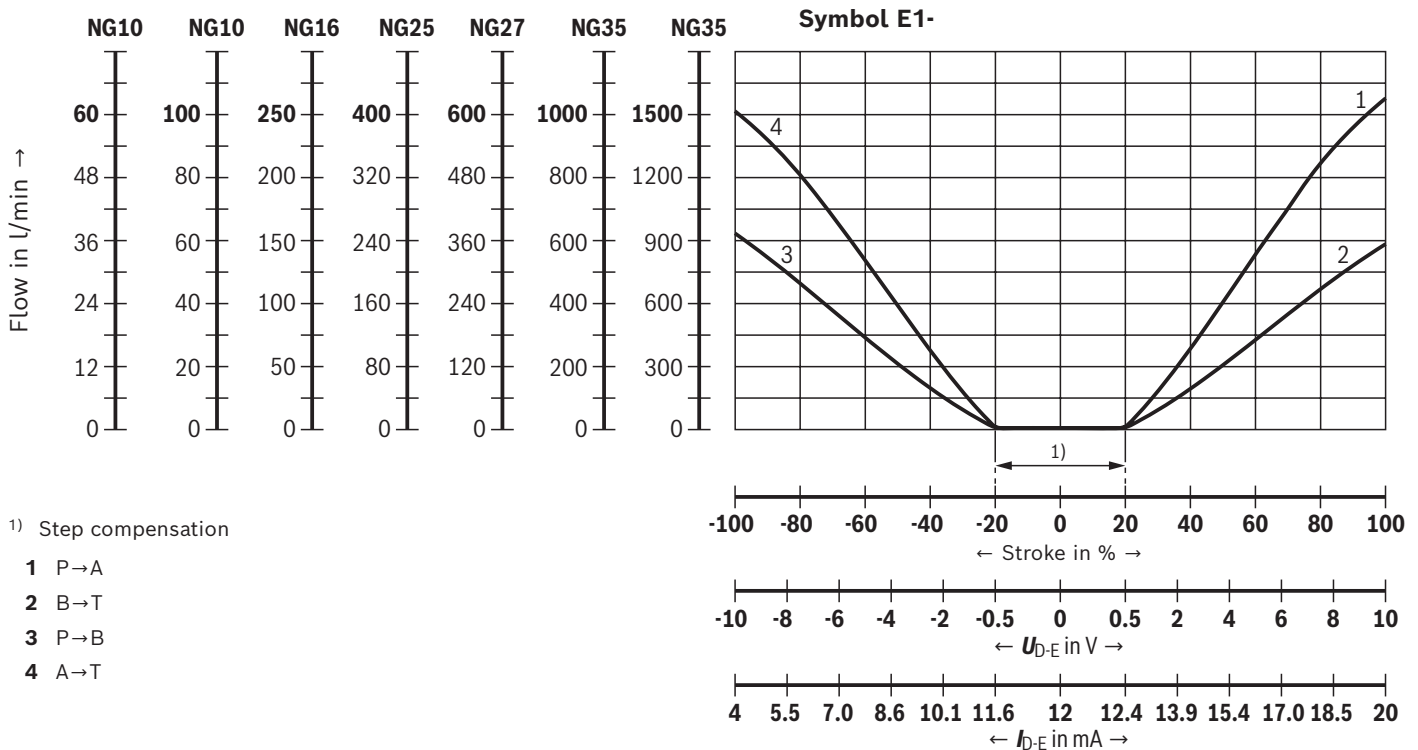
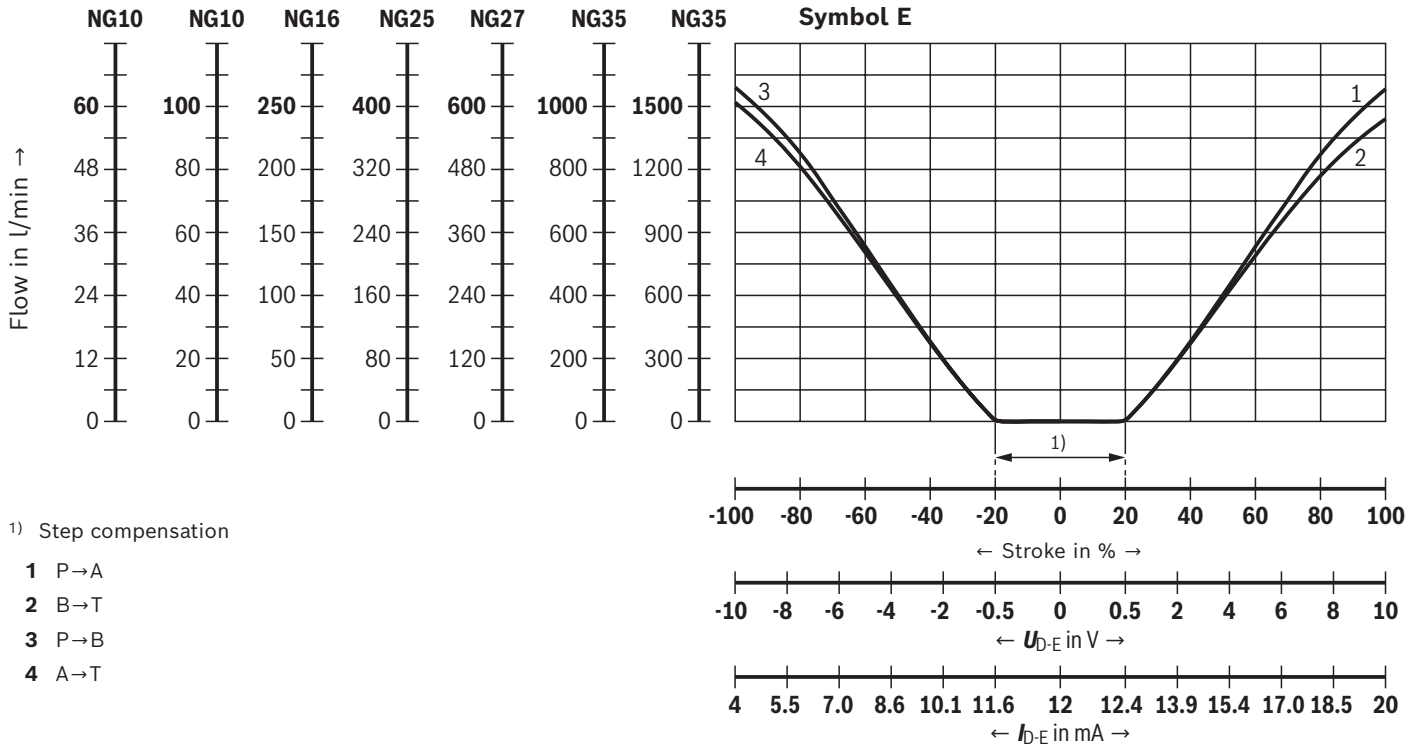

Notice:
 Typical characteristic curves which are subject to tolerance variations.

Characteristic curves: Flow characteristic "L"
 (valid for HLP46, $\vartheta_{oil} = 40 \pm 5 \text{ }^\circ\text{C}$; $\Delta p = 5 \text{ bar}$ per control edge)

Flow/signal function

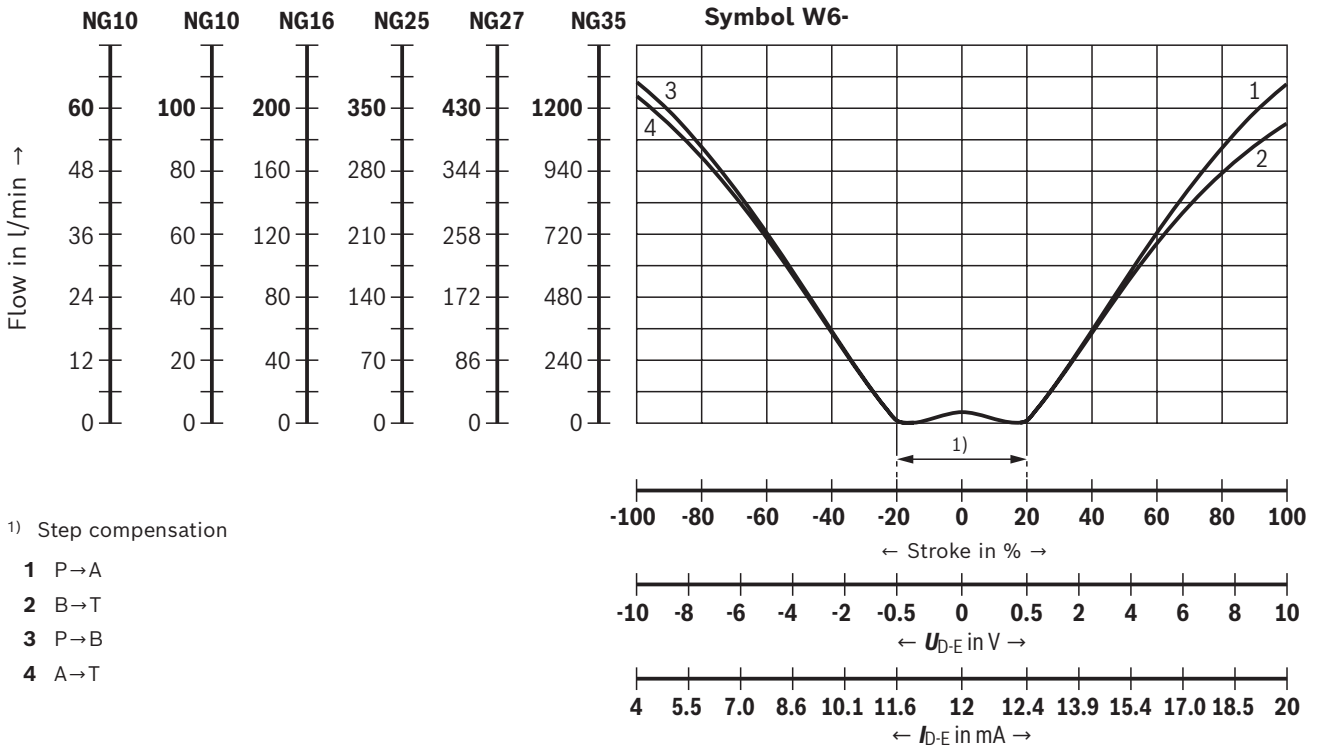

1) Step compensation

- 1 P → A
- 2 B → T
- 3 P → B
- 4 A → T

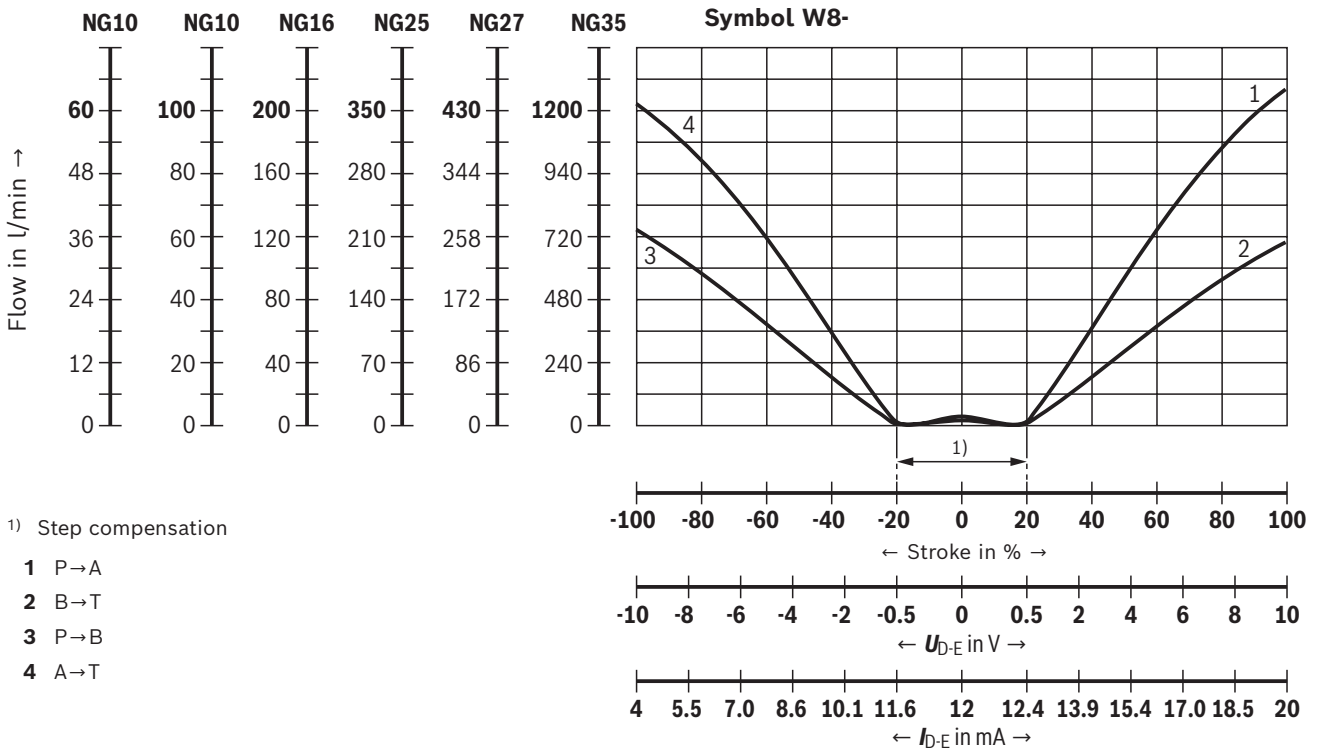

1) Step compensation

- 1 P → A
- 2 B → T
- 3 P → B
- 4 A → T

Notice:
 Typical characteristic curves which are subject to tolerance variations.

Characteristic curves: Flow characteristic "L"
 (valid for HLP46, $\vartheta_{oil} = 40 \pm 5 \text{ }^\circ\text{C}$; $\Delta p = 5 \text{ bar}$ per control edge)

Flow/signal function

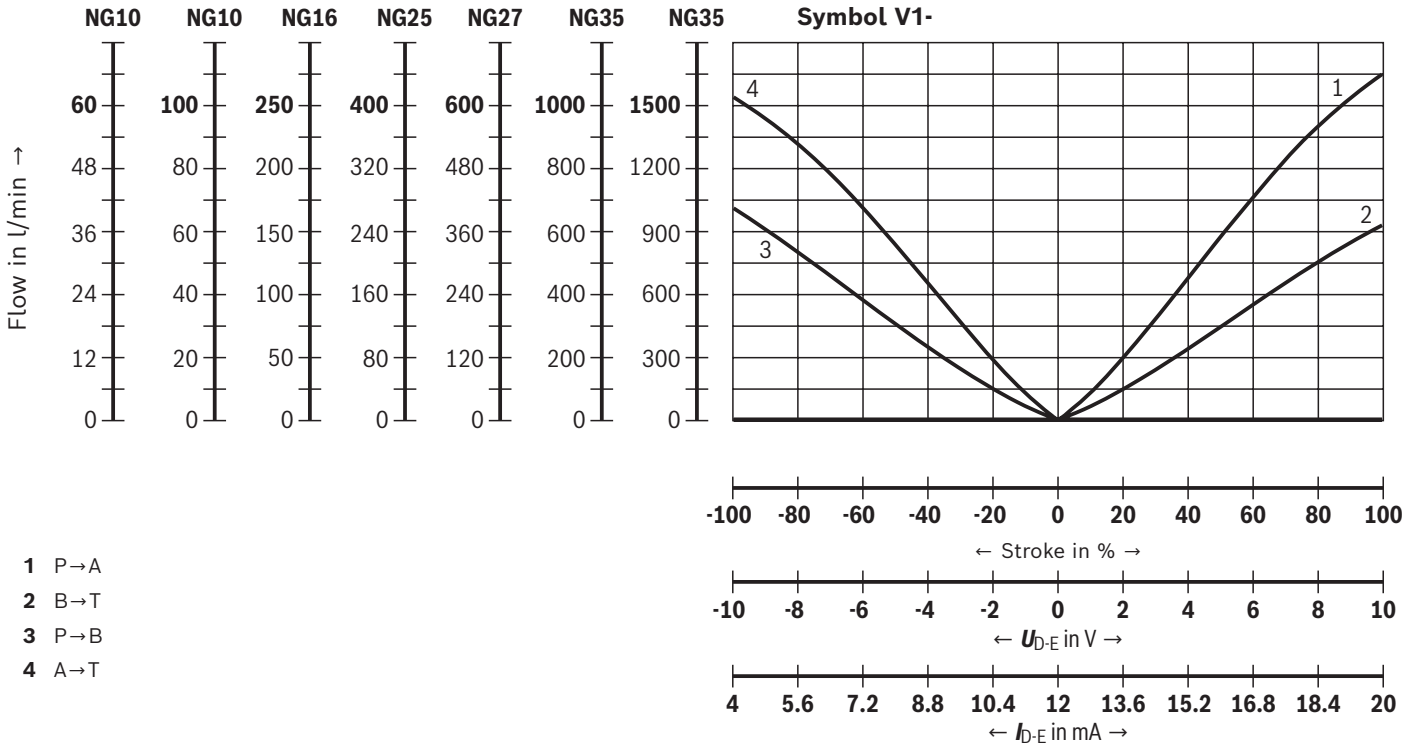
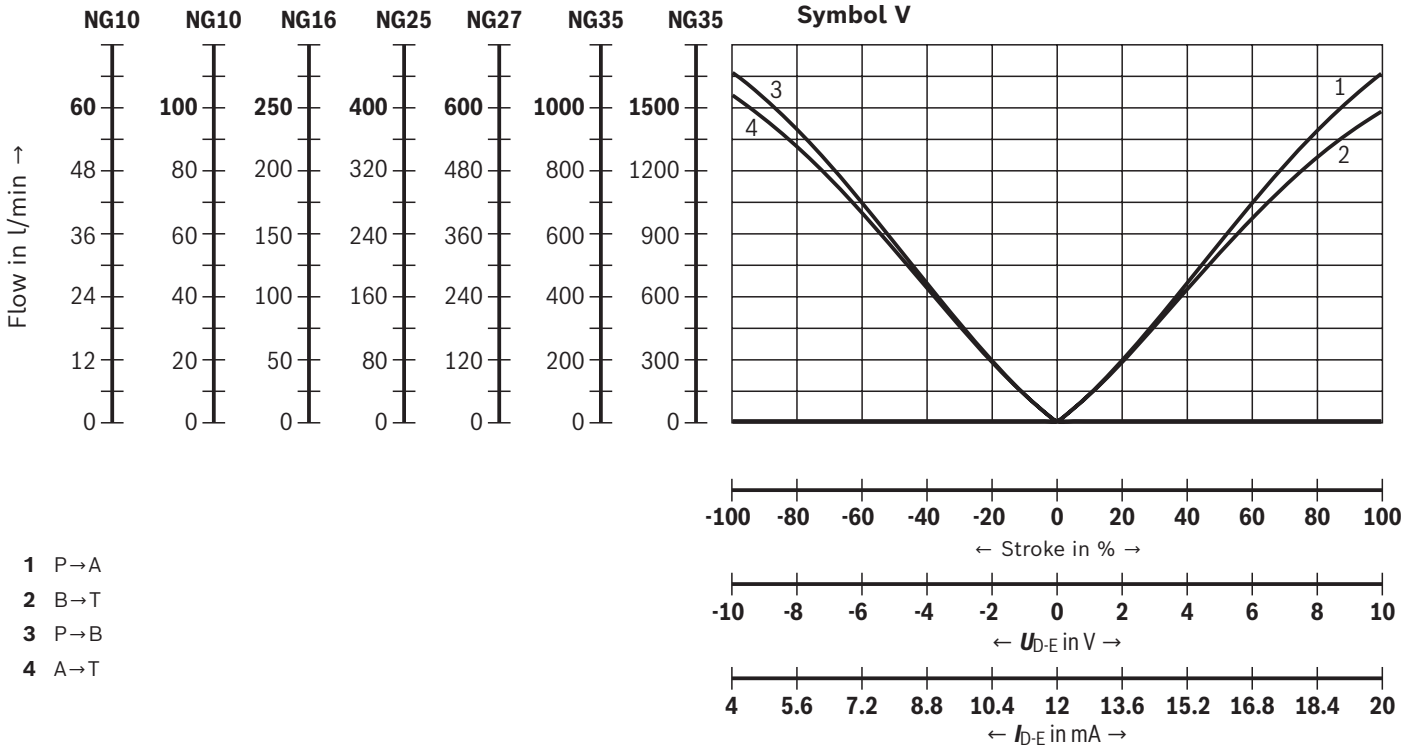

Notice:
 Typical characteristic curves which are subject to tolerance variations.

Characteristic curves: Flow characteristic "P"
 (valid for HLP46, $\vartheta_{oil} = 40 \pm 5 \text{ }^\circ\text{C}$; $\Delta p = 5 \text{ bar}$ per control edge)

Flow/signal function

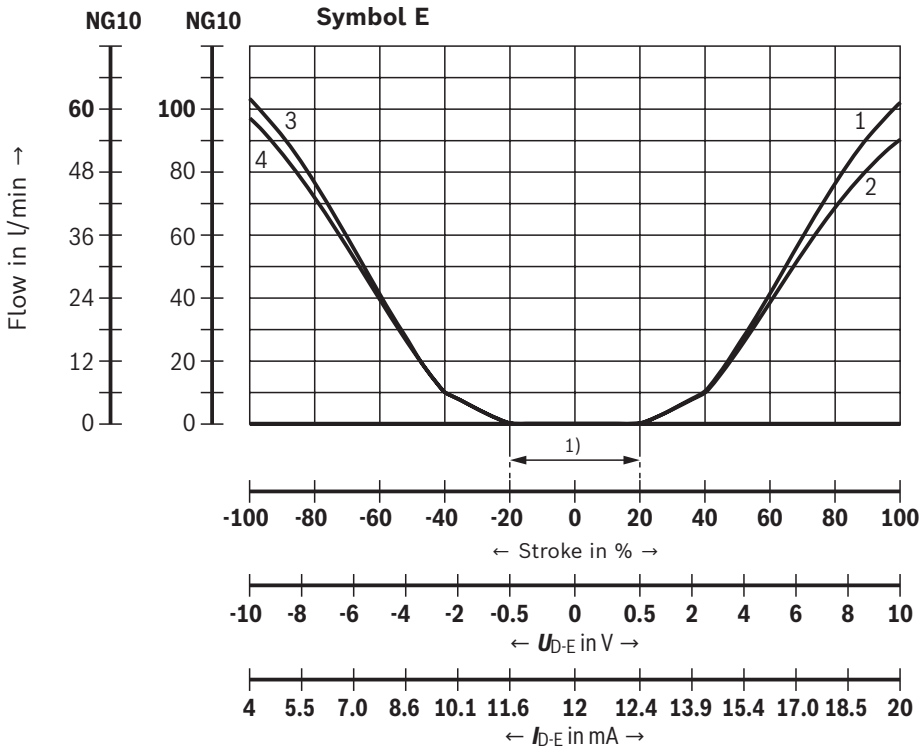

1) Step compensation

- 1 P \rightarrow A
- 2 B \rightarrow T
- 3 P \rightarrow B
- 4 A \rightarrow T

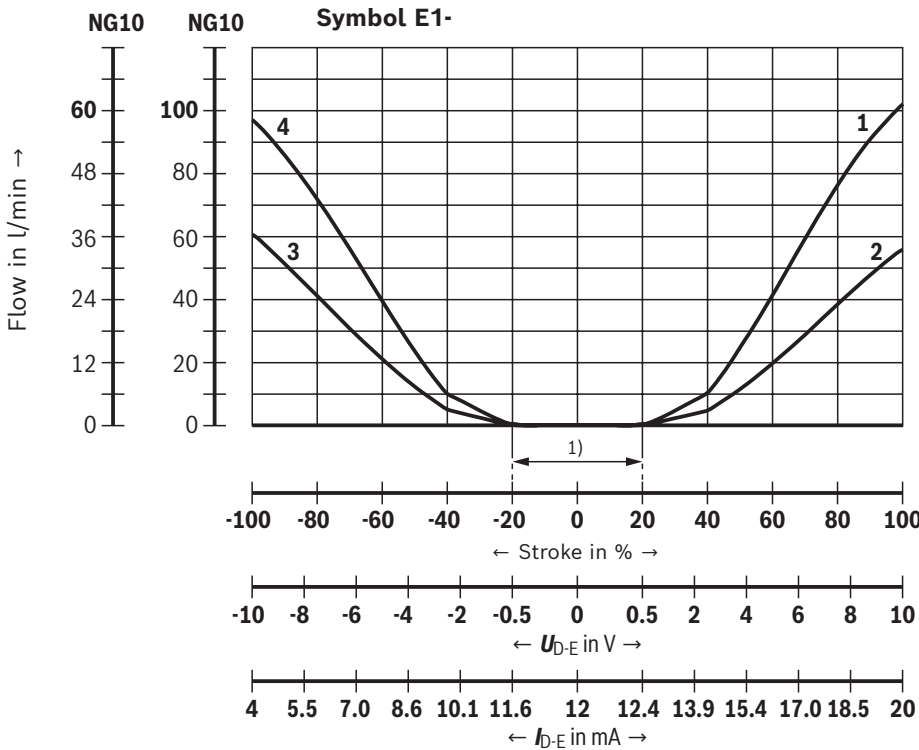

1) Step compensation

- 1 P \rightarrow A
- 2 B \rightarrow T
- 3 P \rightarrow B
- 4 A \rightarrow T



Notice:

Typical characteristic curves which are subject to tolerance variations.

Characteristic curves: Flow characteristic "P"
 (valid for HLP46, $\vartheta_{oil} = 40 \pm 5 \text{ }^\circ\text{C}$; $\Delta p = 5 \text{ bar}$ per control edge)

Flow/signal function

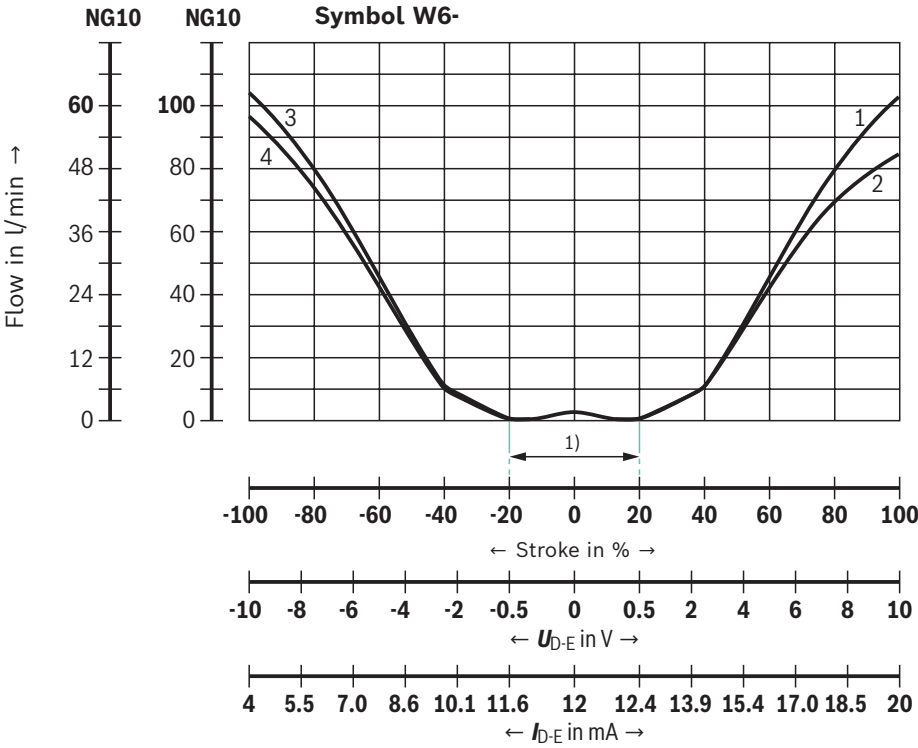

1) Step compensation

- 1 P→A
- 2 B→T
- 3 P→B
- 4 A→T

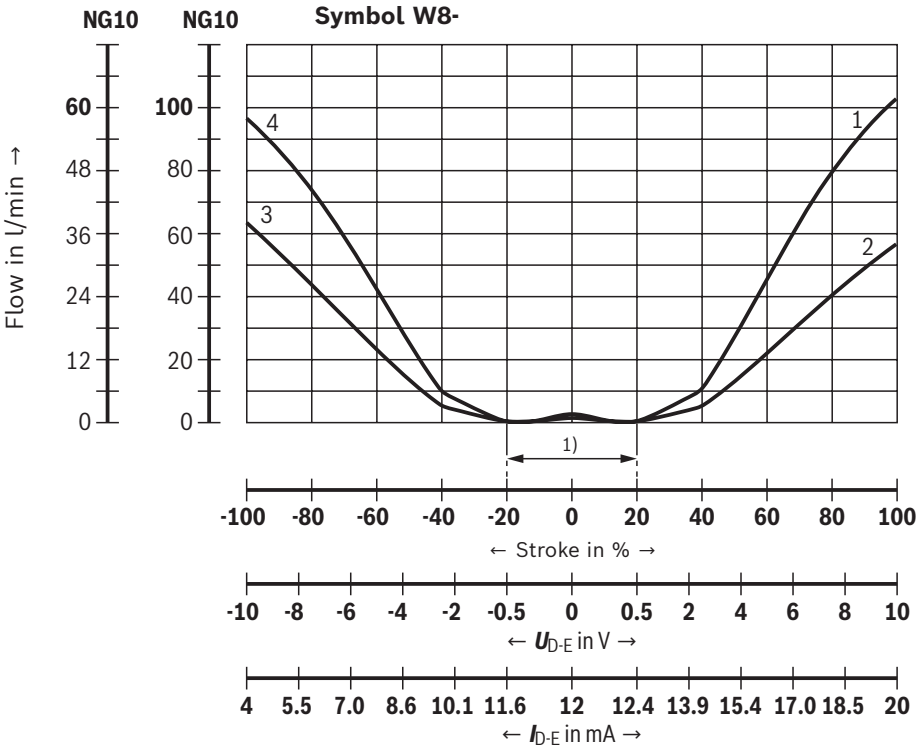

1) Step compensation

- 1 P→A
- 2 B→T
- 3 P→B
- 4 A→T

Notice:
 Typical characteristic curves which are subject to tolerance variations.

Characteristic curves: Flow characteristic "P"
 (valid for HLP46, $\vartheta_{oil} = 40 \pm 5 \text{ } ^\circ\text{C}$; $\Delta p = 5 \text{ bar}$ per control edge)

Flow/signal function

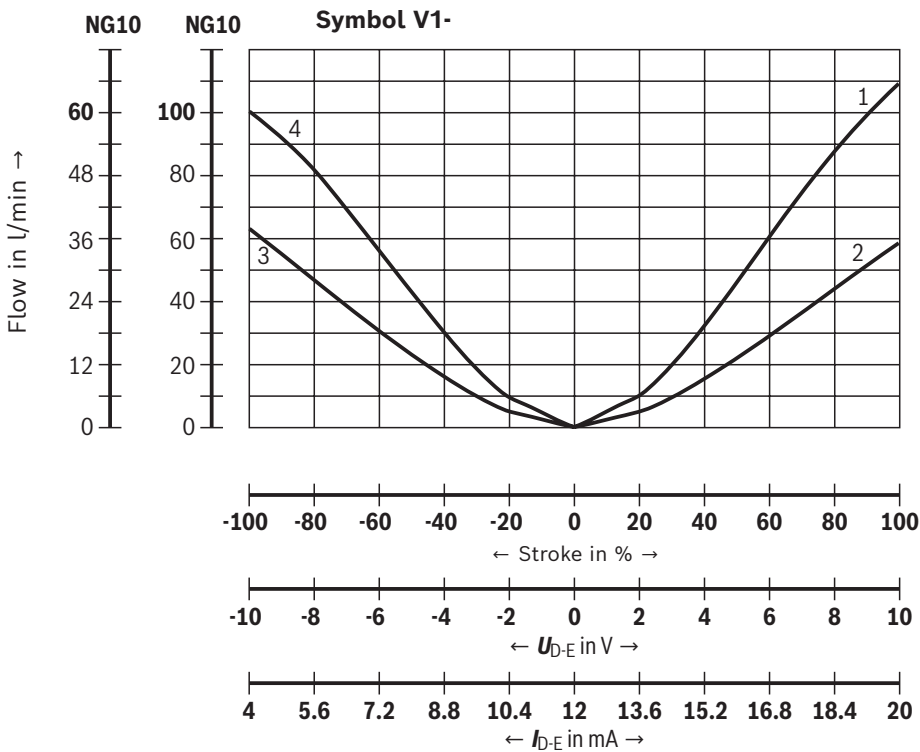
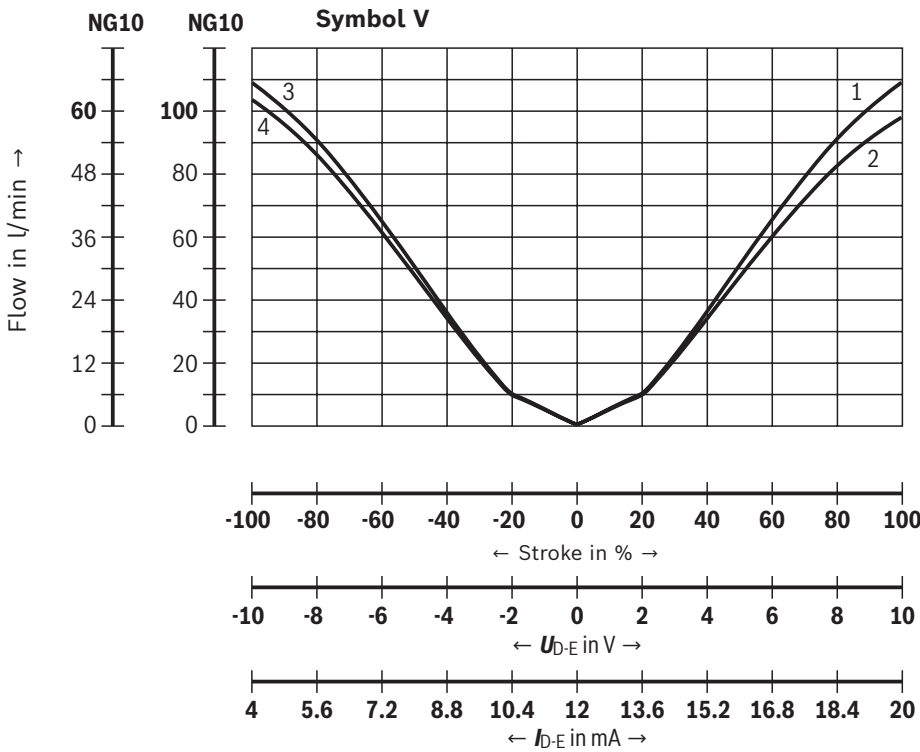

Notice:

Typical characteristic curves which are subject to tolerance variations.

Characteristic curves: Flow characteristic "M"
 (valid for HLP46, $\vartheta_{oil} = 40 \pm 5 \text{ }^\circ\text{C}$; $\Delta p = 5 \text{ bar}$ per control edge)

Flow/signal function

Symbol Q3, version "100"

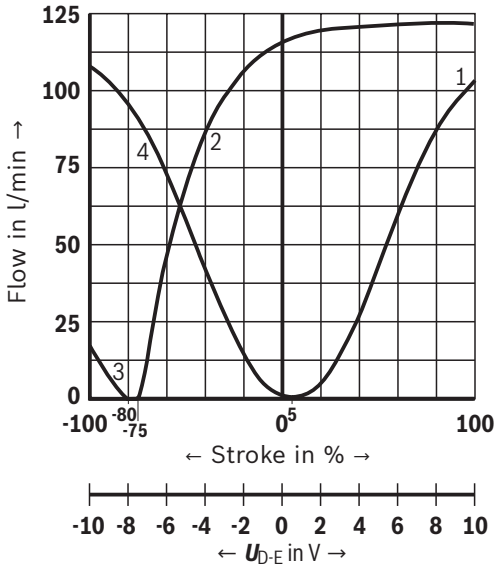

Symbol Q3, version "250"

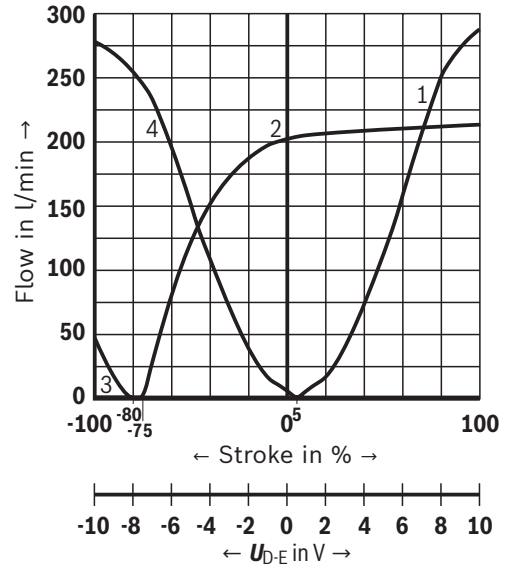

Symbol Q3, version "400"

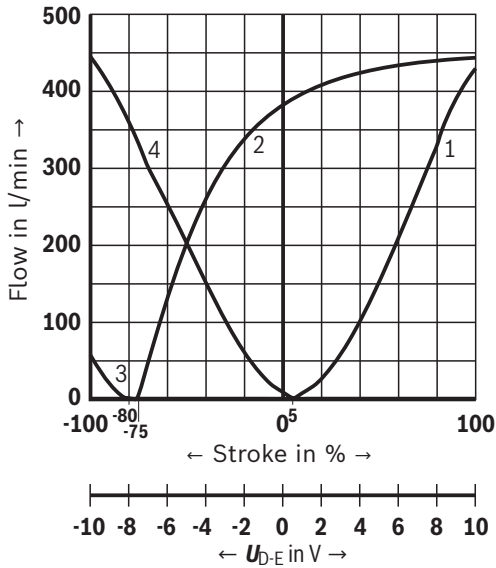

Symbol Q3, version "600"

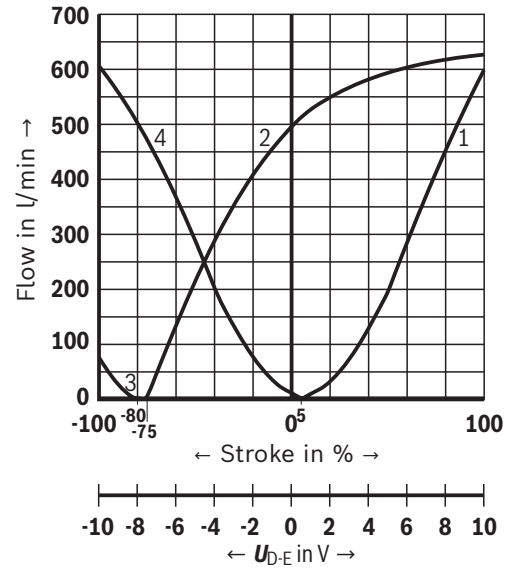

Notice:

Typical characteristic curves which are subject to tolerance variations.

Characteristic curves: Flow characteristic "M"
 (valid for HLP46, $\vartheta_{oil} = 40 \pm 5 \text{ }^\circ\text{C}$; $\Delta p = 5 \text{ bar}$ per control edge)

Flow/signal function

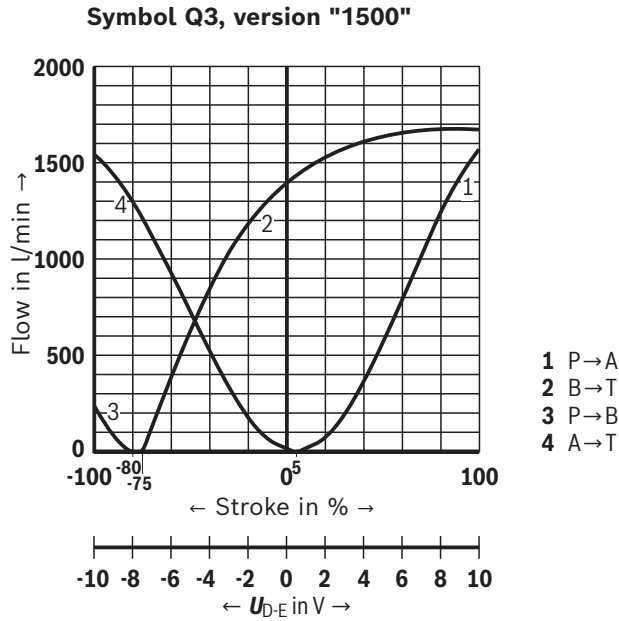

Notice:
 Typical characteristic curves which are subject to tolerance variations.

Characteristic curves
 (measured with HLP46, $\vartheta_{oil} = 40 \pm 5 \text{ }^\circ\text{C}$)

Pressure-signal characteristic curve

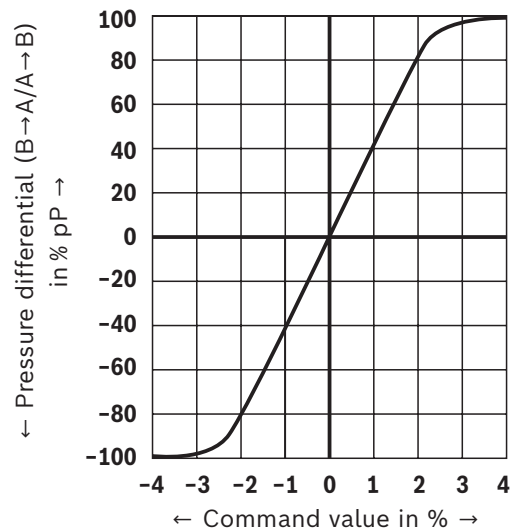
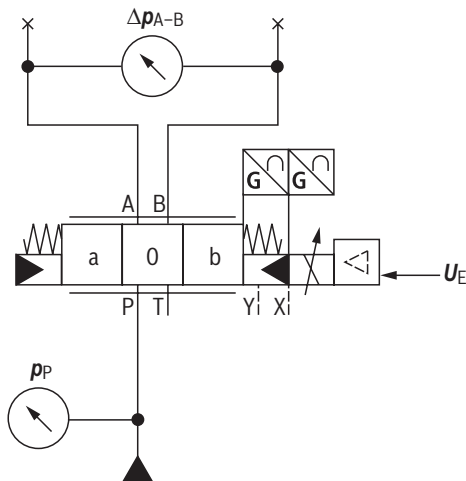

Characteristic curves: Size 10
(measured with HLP46, $\vartheta_{oil} = 40 \pm 5 \text{ } ^\circ\text{C}$)

Transition function with stepped electric input signals

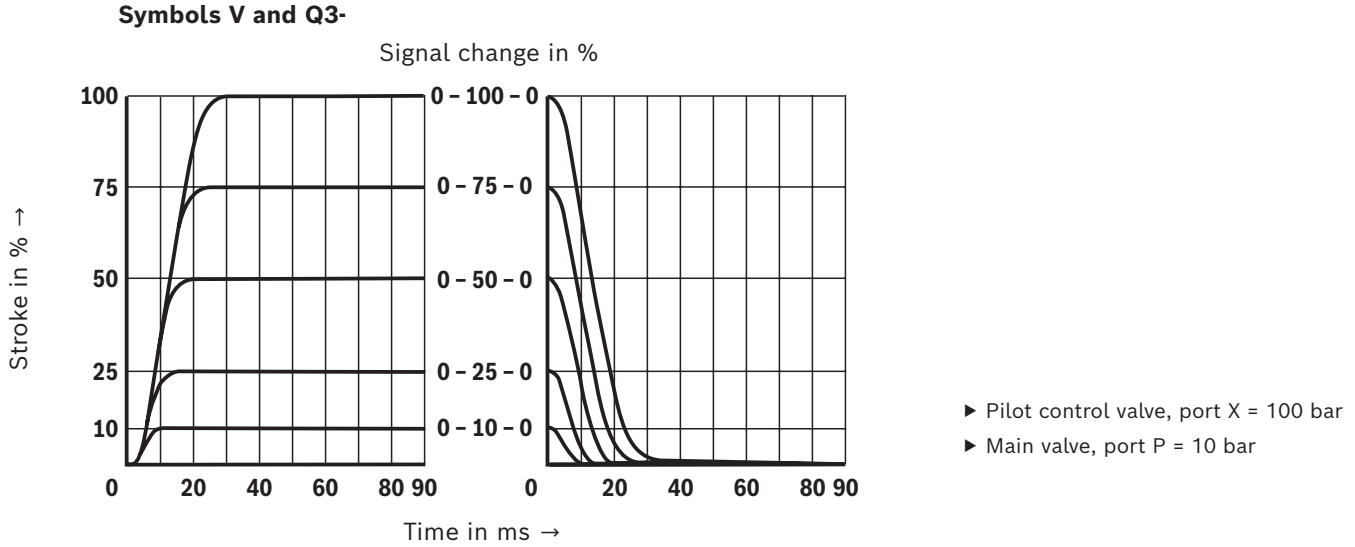

Frequency response

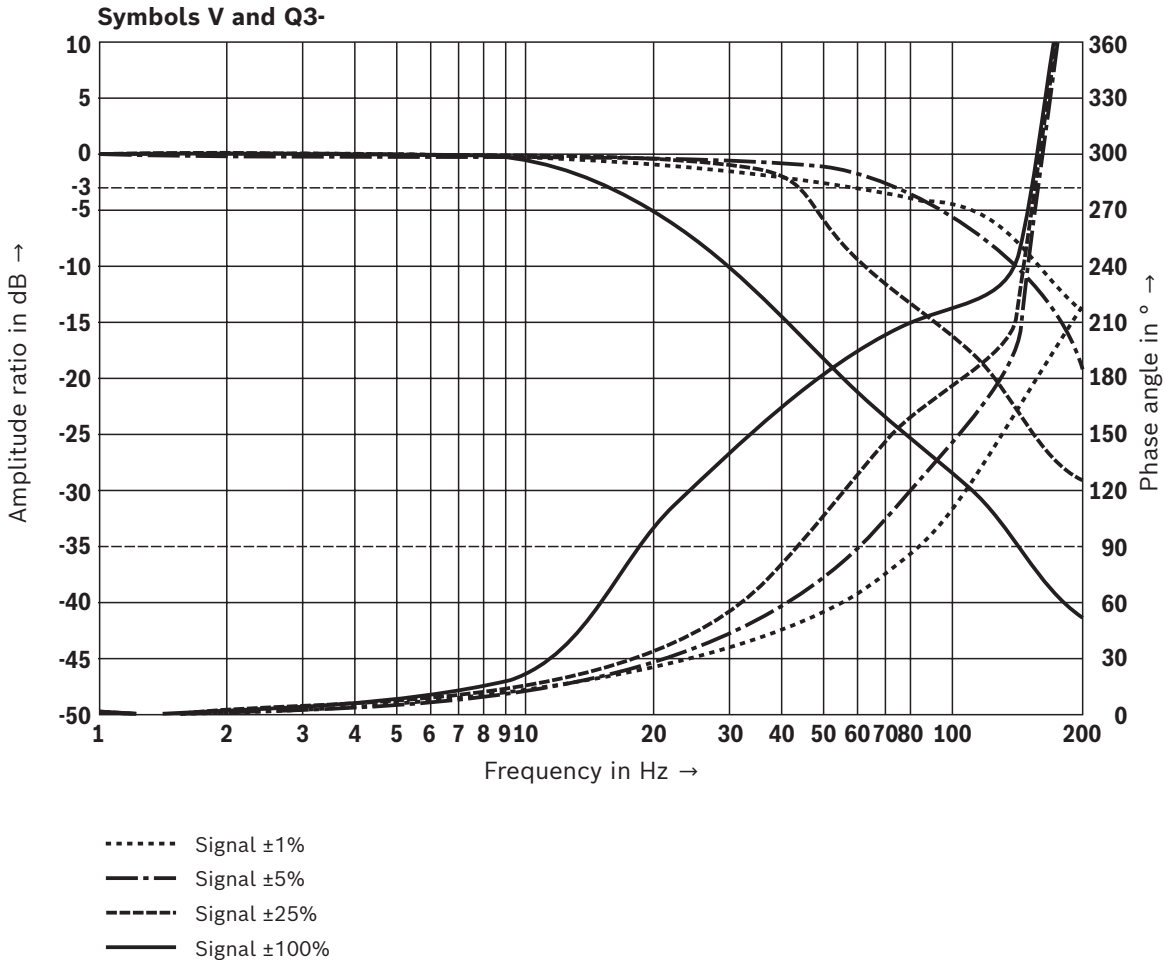

Characteristic curves: Size 10
(valid for HLP46, $\vartheta_{oil} = 40 \pm 5 \text{ } ^\circ\text{C}$)

Flow/load function (with maximum valve opening; tolerance $\pm 10\%$)

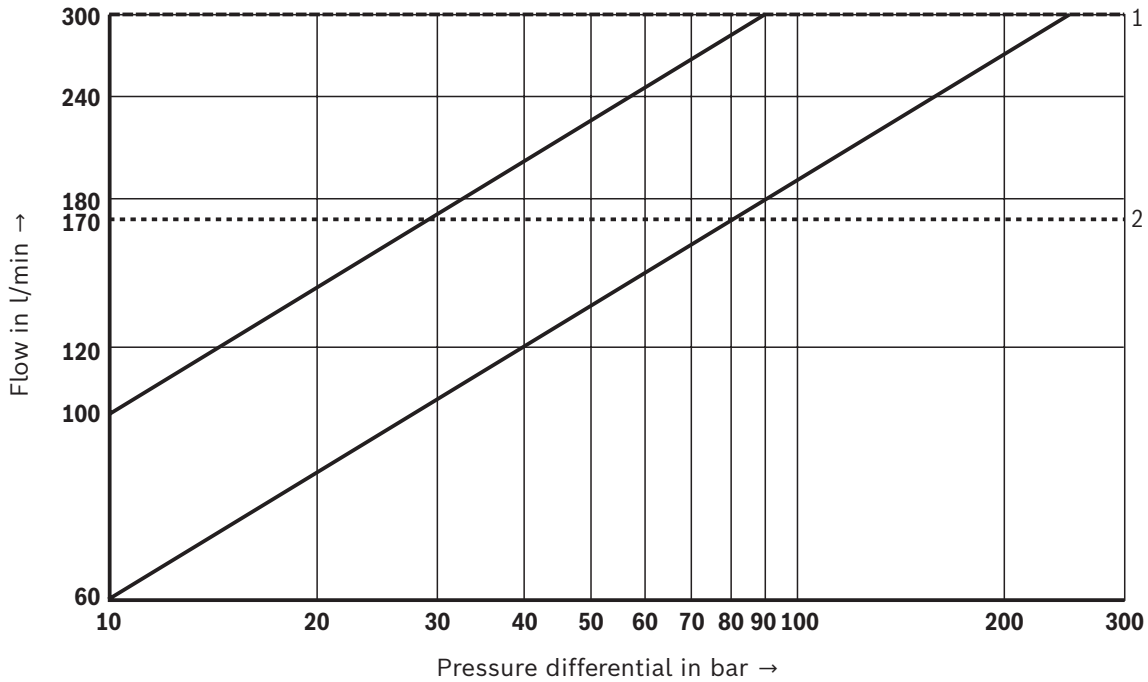

- 1 Maximum flow
- 2 Recommended flow
(flow velocity 30 m/s)

Characteristic curves: Size 16
(measured with HLP46, $\vartheta_{oil} = 40 \pm 5 \text{ } ^\circ\text{C}$)

Transition function with stepped electric input signals

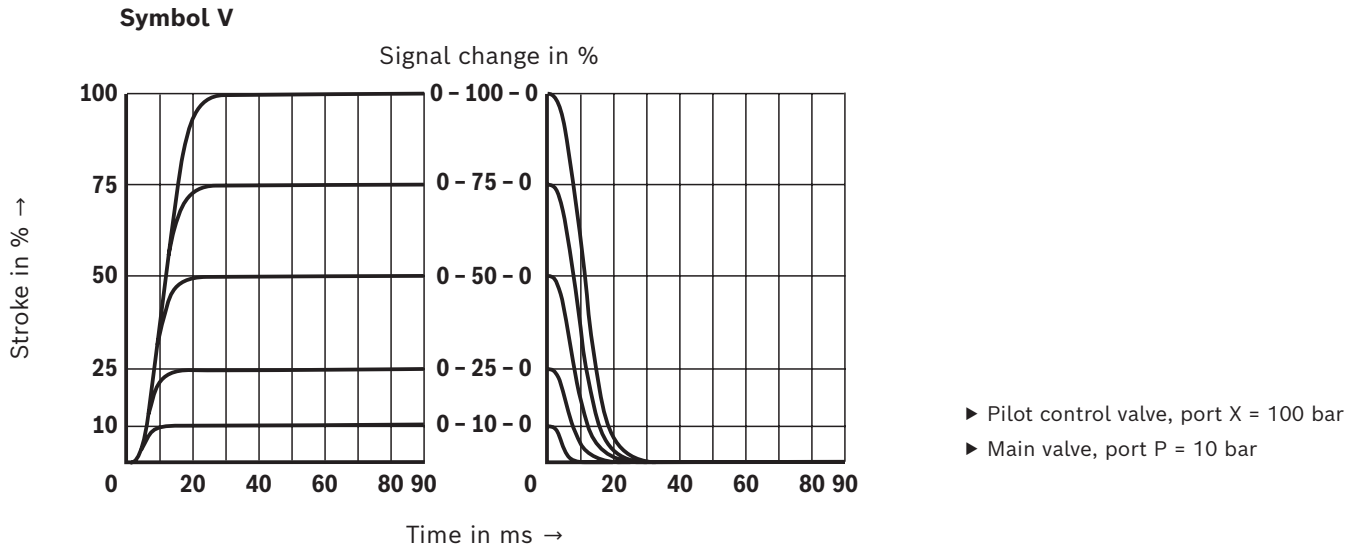

Frequency response

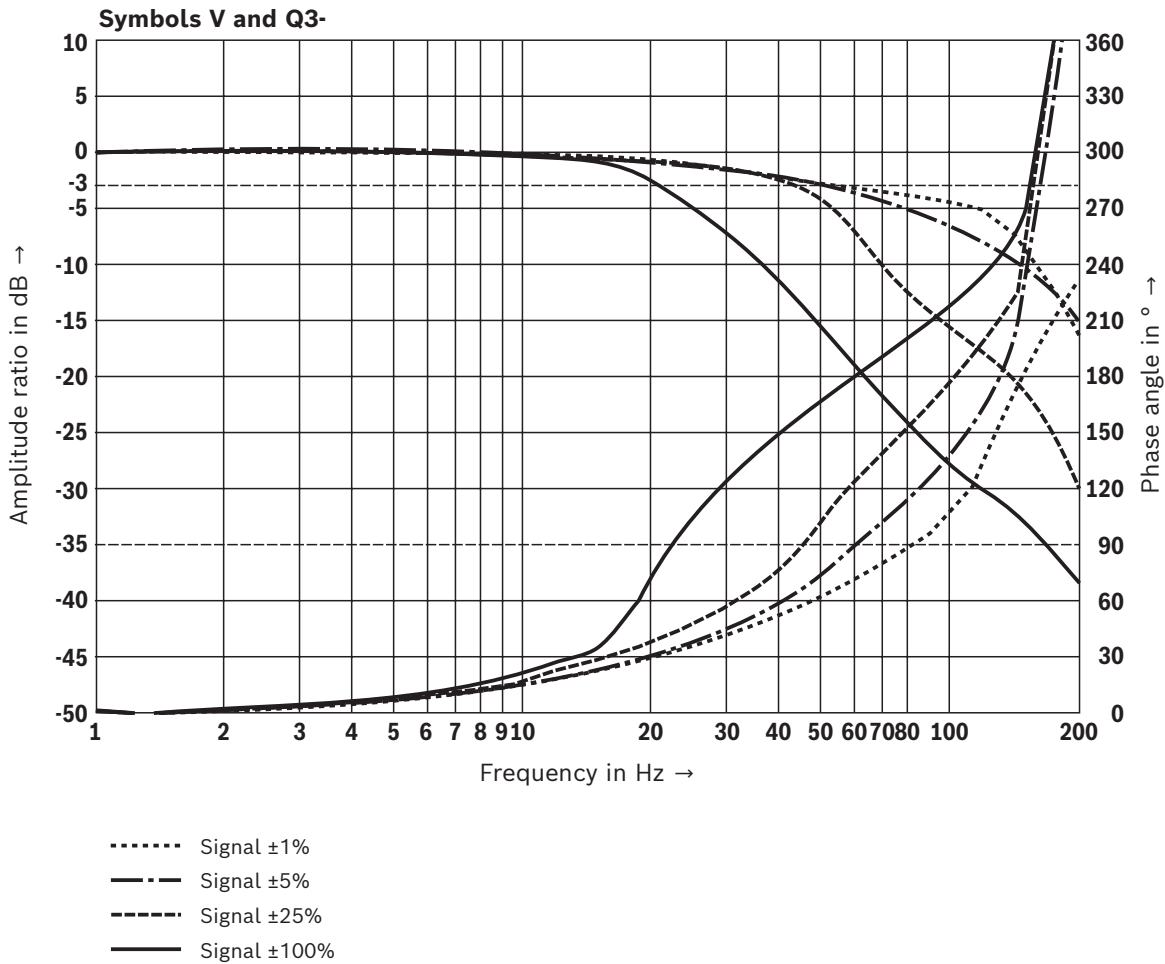

Characteristic curves: Size 16
(measured with HLP46, $\vartheta_{oil} = 40 \pm 5 \text{ } ^\circ\text{C}$)

Flow/load function (with maximum valve opening; tolerance $\pm 10\%$)

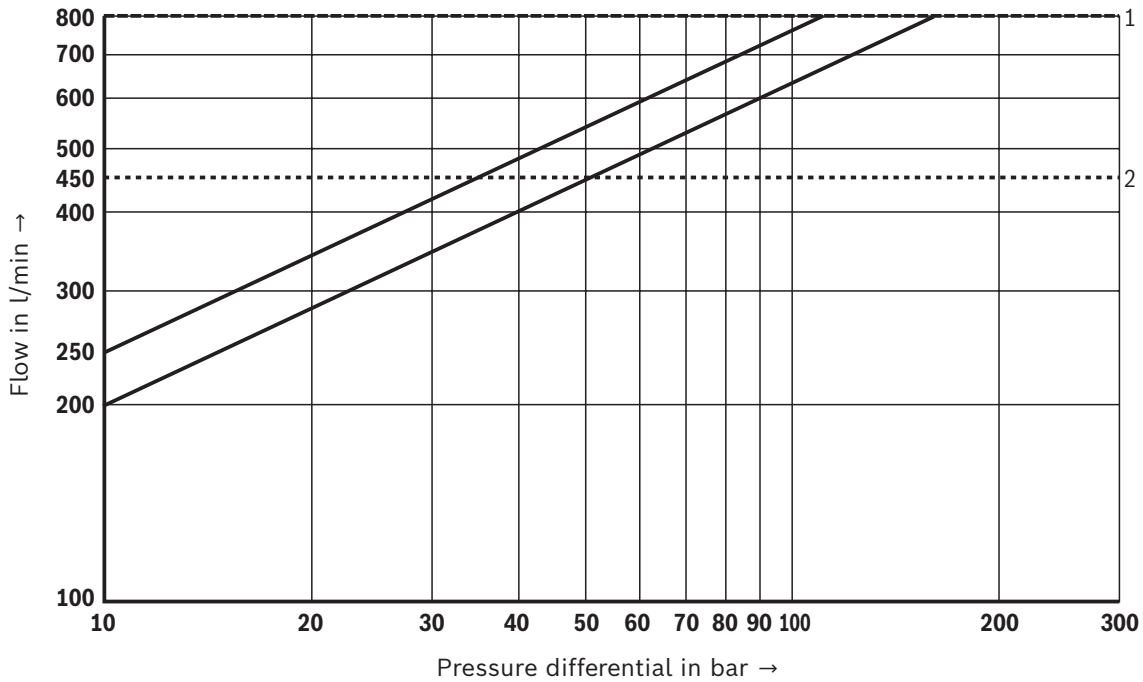

- 1 Maximum flow
- 2 Recommended flow limitation
(flow velocity 30 m/s)

Characteristic curves: Size 25
(measured with HLP46, $\vartheta_{oil} = 40 \pm 5 \text{ } ^\circ\text{C}$)

Transition function with stepped electric input signals

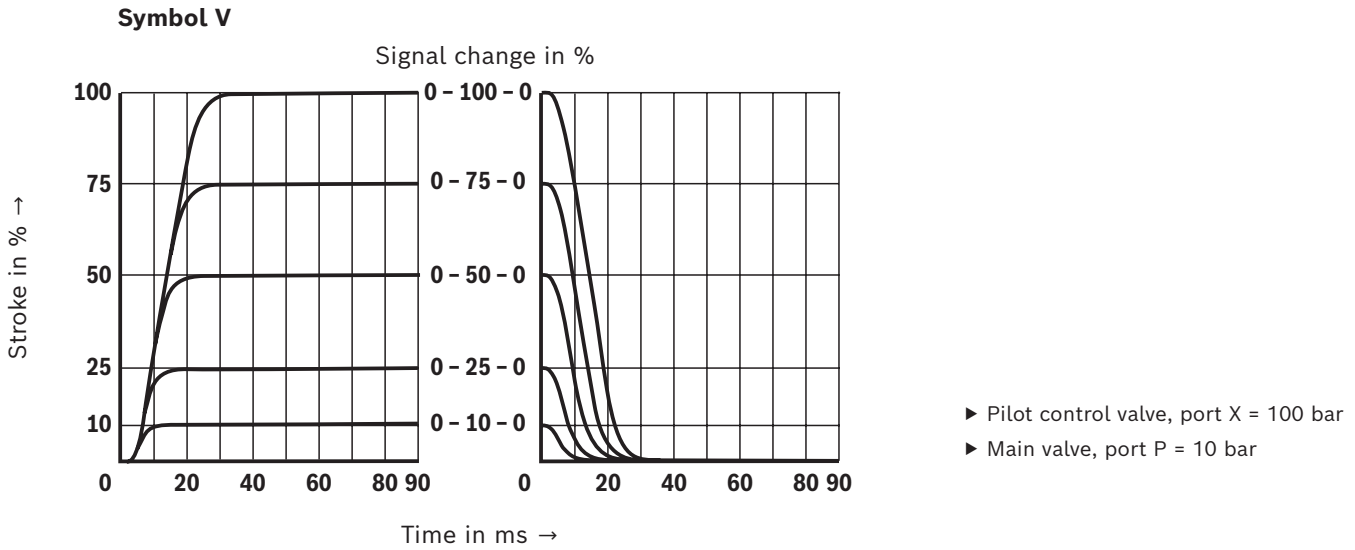

Frequency response

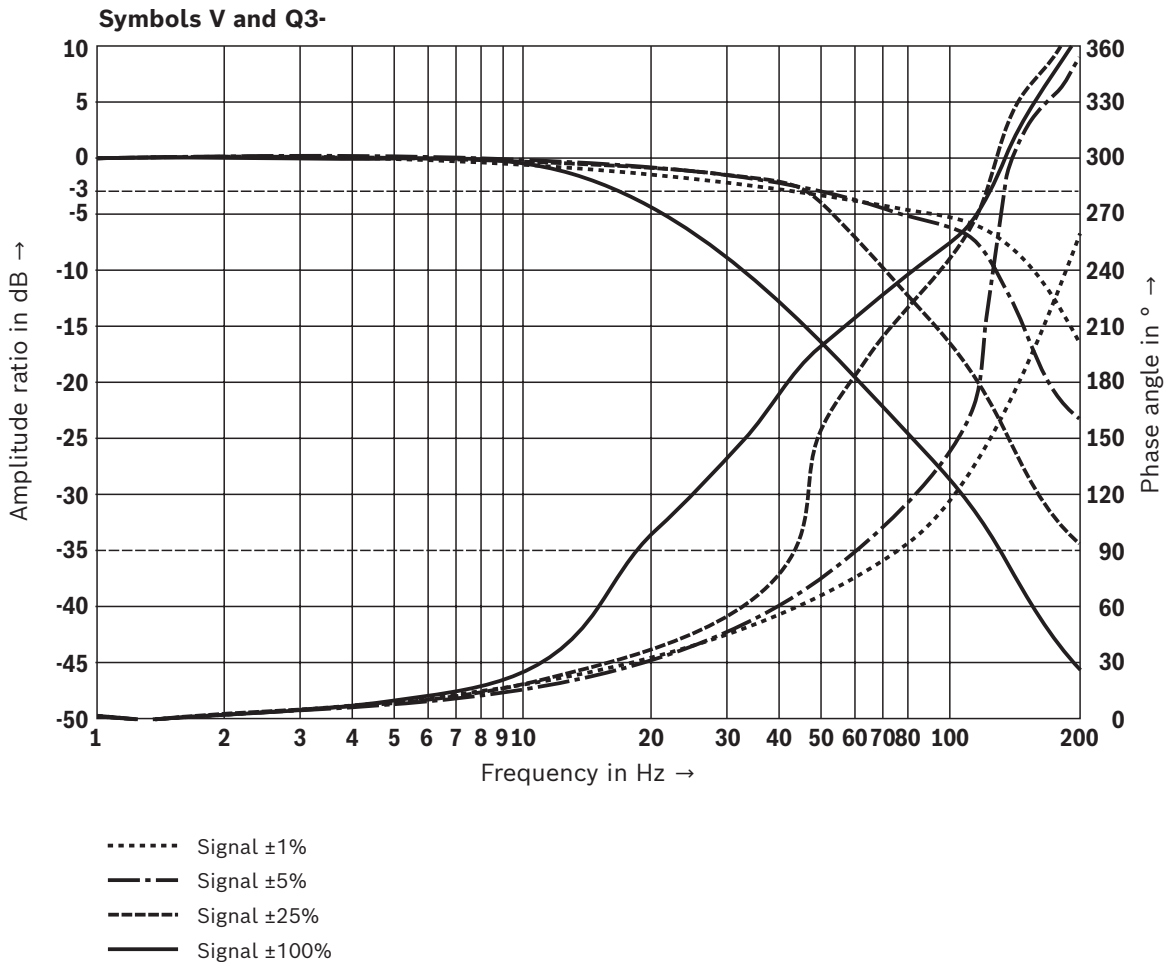

Characteristic curves: Size 25
(measured with HLP46, $\vartheta_{oil} = 40 \pm 5 \text{ } ^\circ\text{C}$)

Flow/load function (with maximum valve opening; tolerance $\pm 10\%$)

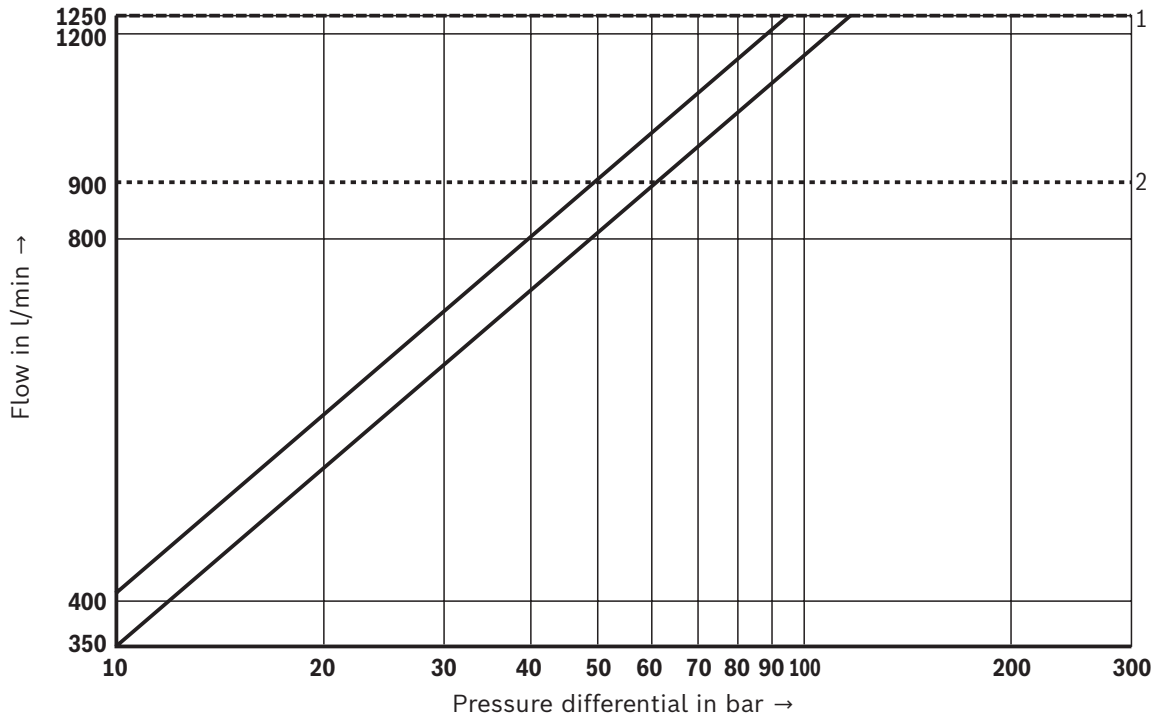

- 1 Maximum flow
- 2 Recommended flow limitation
(flow velocity 30 m/s)

Characteristic curves: Size 27
(measured with HLP46, $\vartheta_{oil} = 40 \pm 5 \text{ } ^\circ\text{C}$)

Transition function with stepped electric input signals

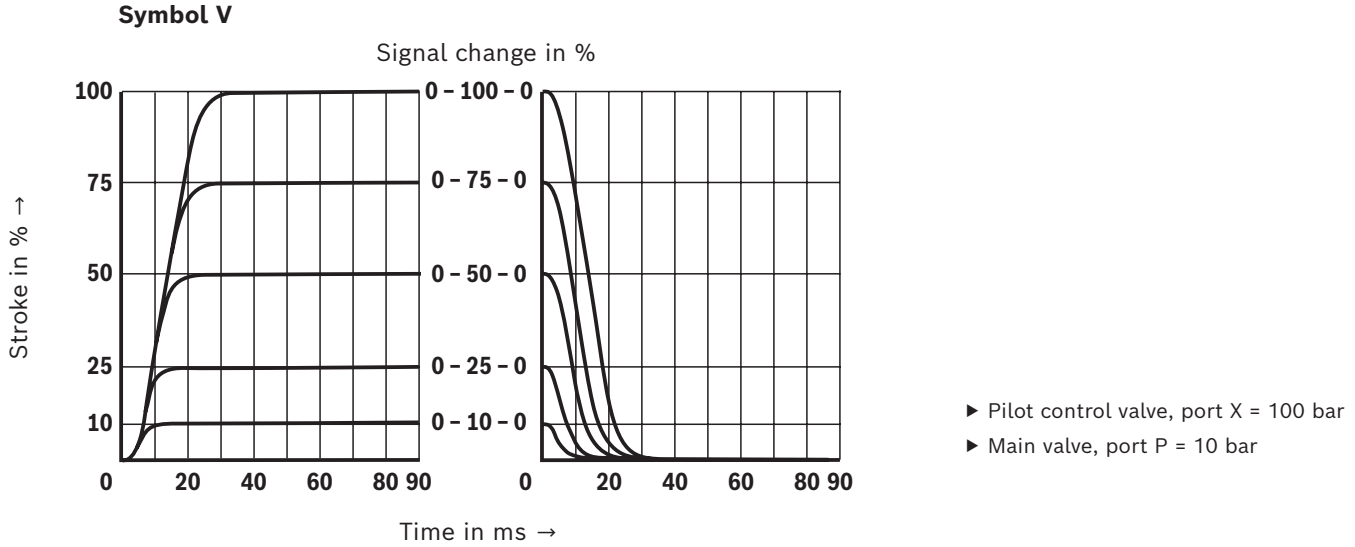

Frequency response

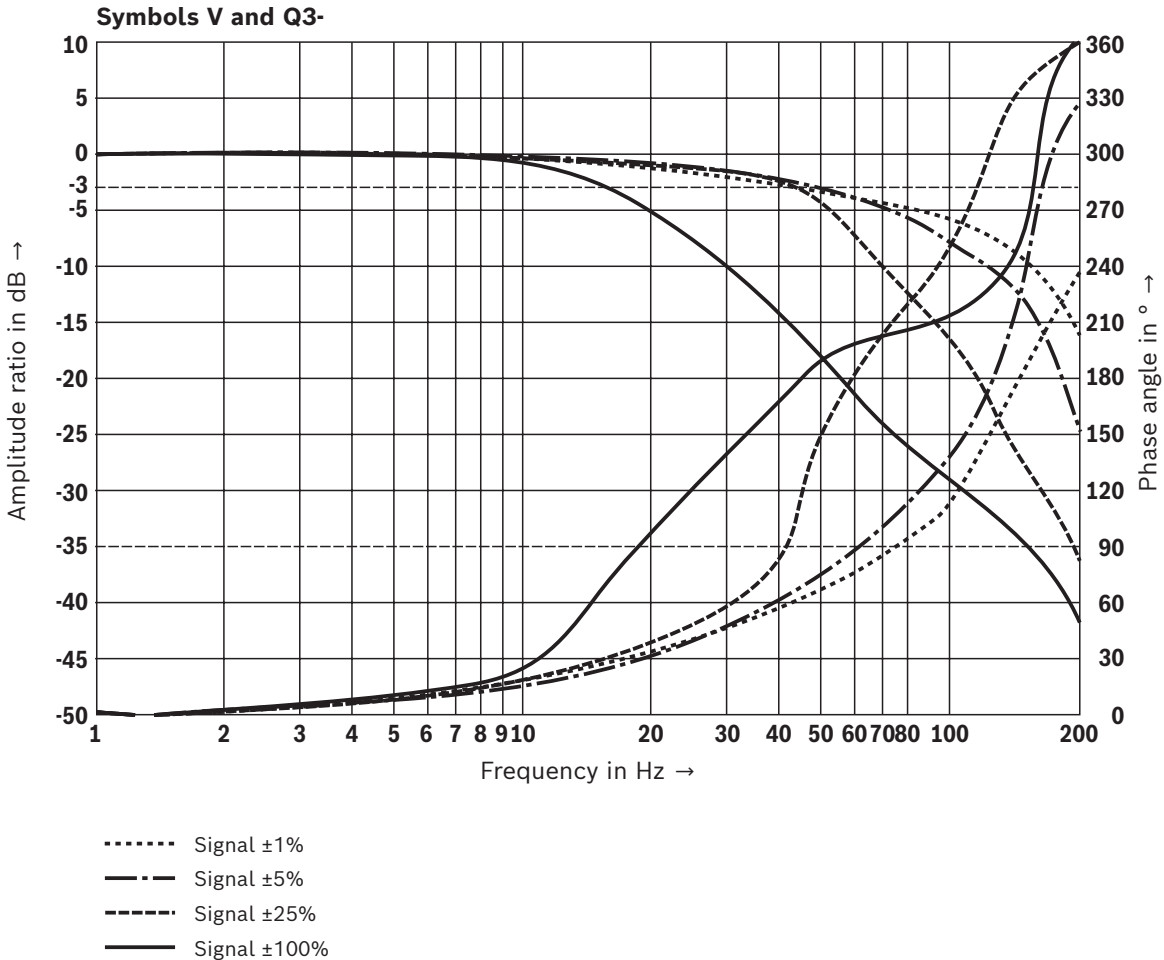

Characteristic curves: Size 27
(measured with HLP46, $\vartheta_{oil} = 40 \pm 5 \text{ } ^\circ\text{C}$)

Flow/load function (with maximum valve opening; tolerance $\pm 10\%$)

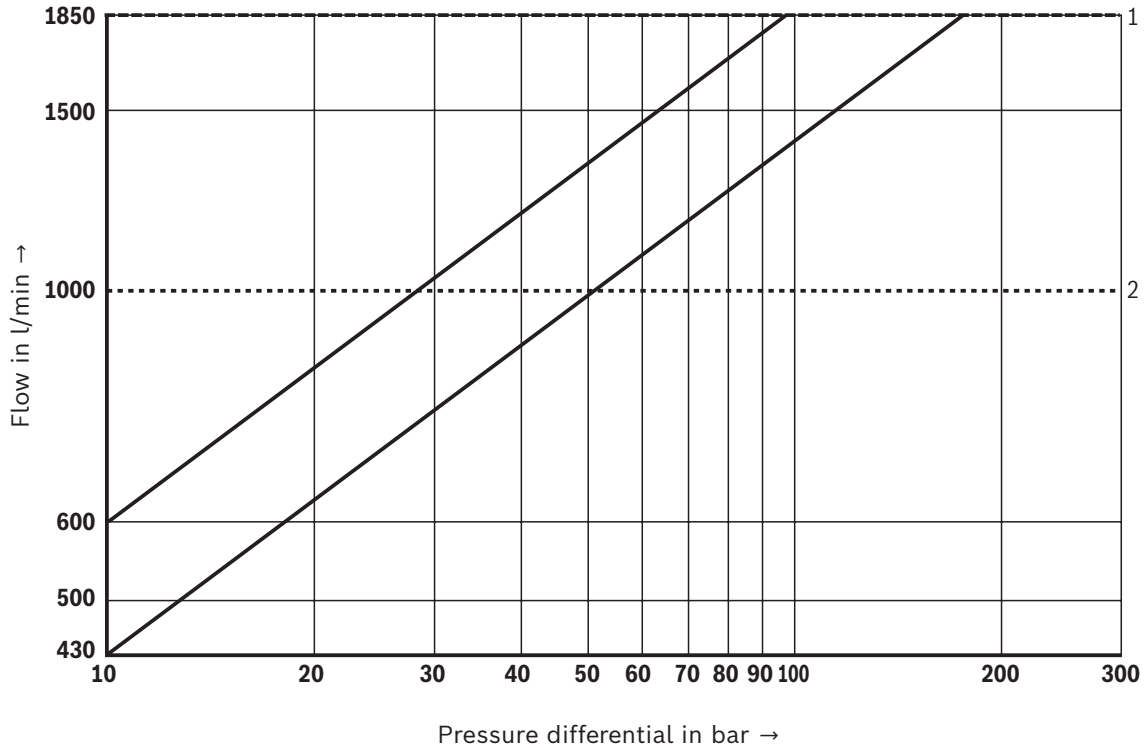

- 1 Maximum flow
- 2 Recommended flow limitation
(flow velocity 30 m/s)

Characteristic curves: Size 35
(measured with HLP46, $\vartheta_{oil} = 40 \pm 5 \text{ }^\circ\text{C}$)

Transition function with stepped electric input signals

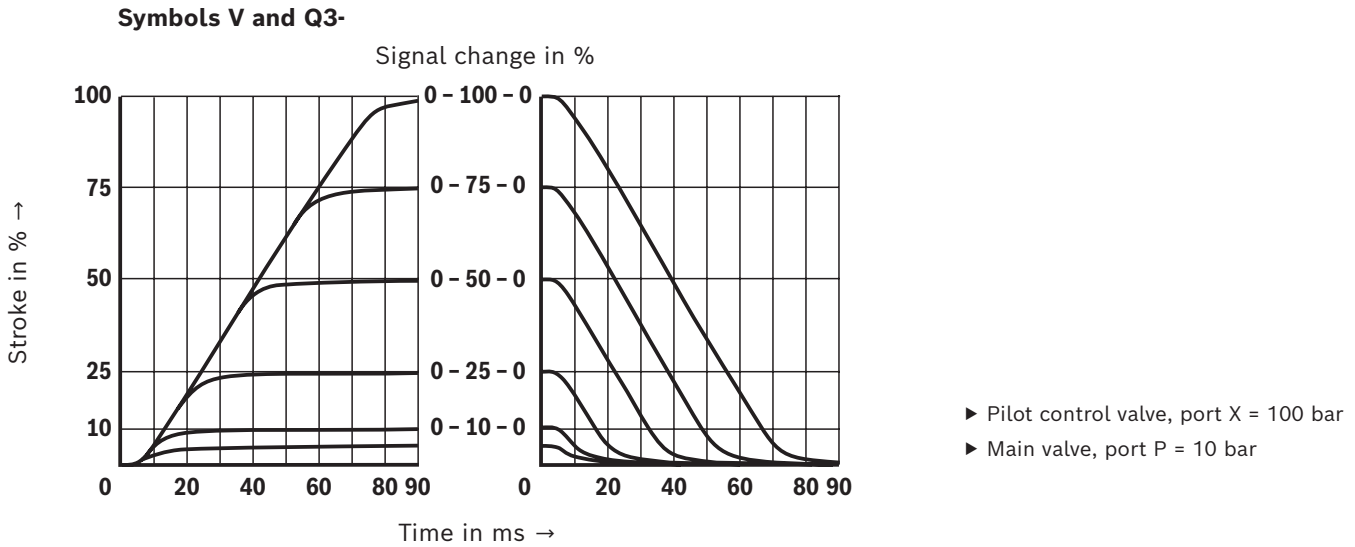

Frequency response characteristic curves

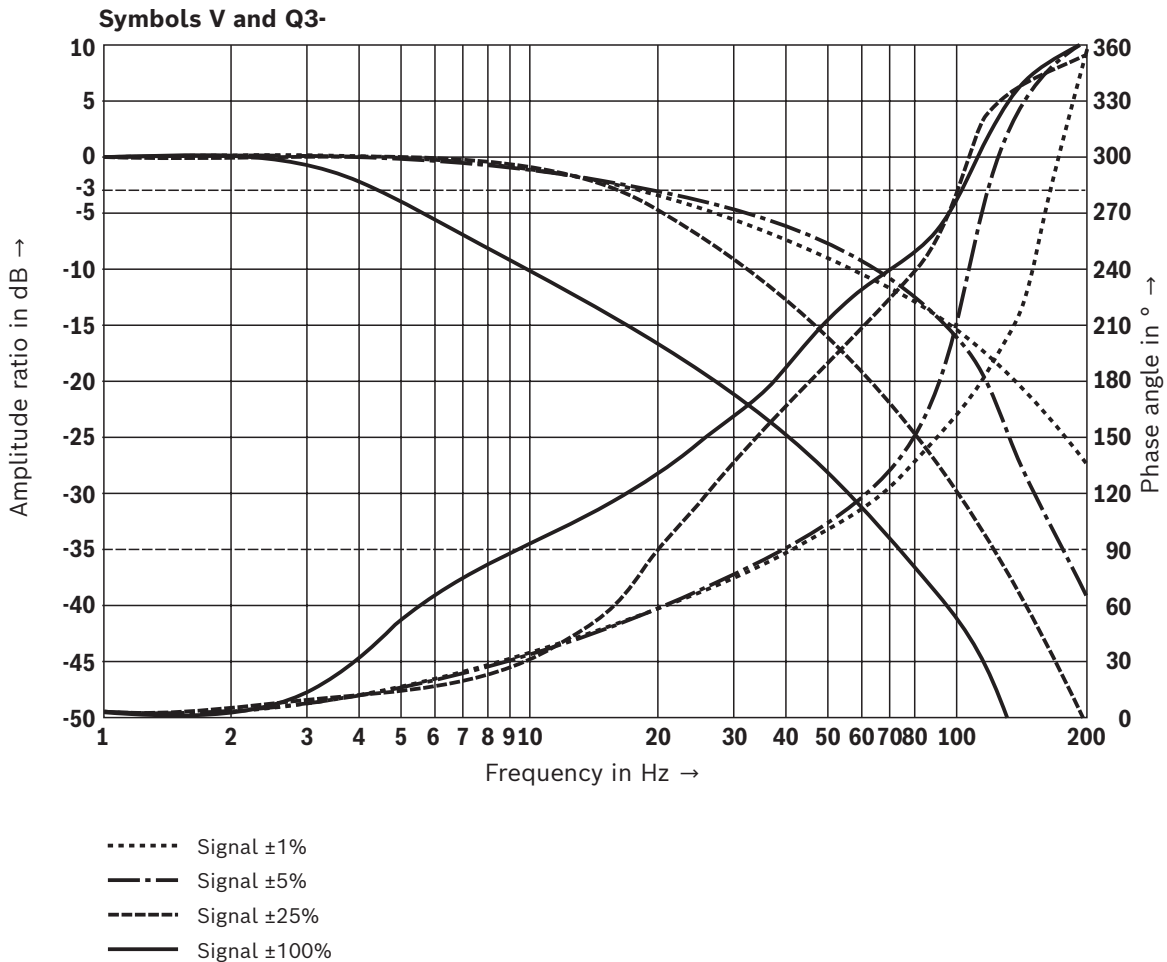

Characteristic curves: Size 35
(valid for HLP46, $\vartheta_{oil} = 40 \pm 5 \text{ } ^\circ\text{C}$)

Flow/load function (with maximum valve opening; tolerance $\pm 10\%$)

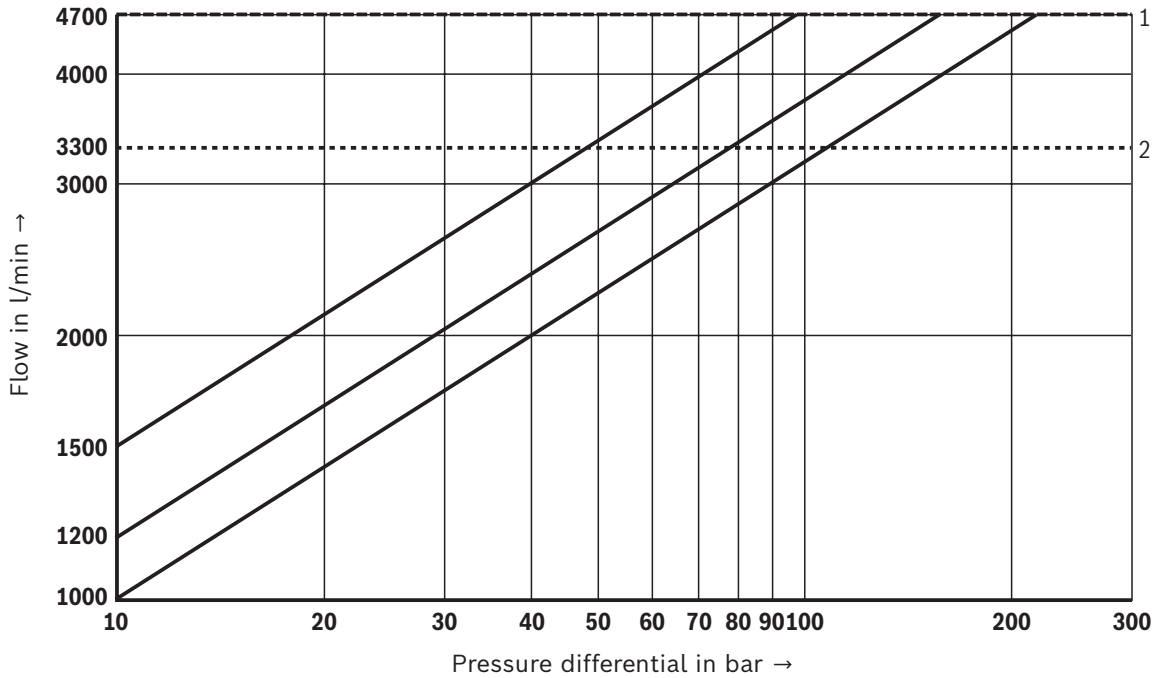

- 1 Maximum flow
- 2 Recommended flow
(flow velocity 30 m/s)

Dimensions: Size 10
(dimensions in mm)

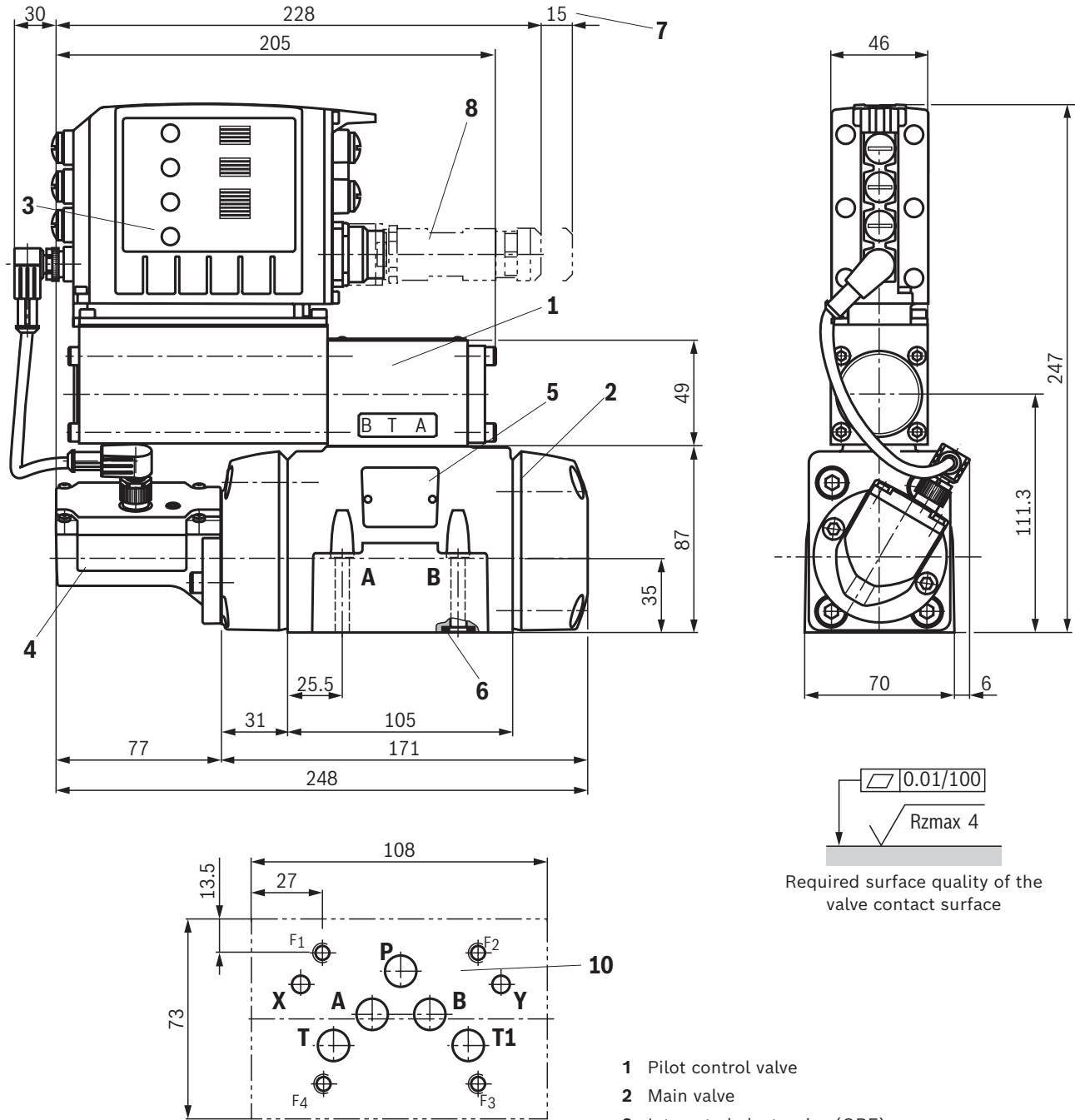

Required surface quality of the valve contact surface

- 1 Pilot control valve
- 2 Main valve
- 3 Integrated electronics (OBE)
- 4 Inductive position transducer (main valve)
- 5 Name plate
- 6 Identical seal rings for ports P, A, B, T
Identical seal rings for ports X, Y
- 7 Space required for removing the mating connector
- 8 Mating connectors, separate order, see page 42 and data sheet 08006.
- 10 Machined valve contact surface, porting pattern according to ISO 4401-05-05-0-05

Valve mounting screws and subplates, see page 41.

Notice:

The dimensions are nominal dimensions which are subject to tolerances.

Dimensions: Size 16
(dimensions in mm)

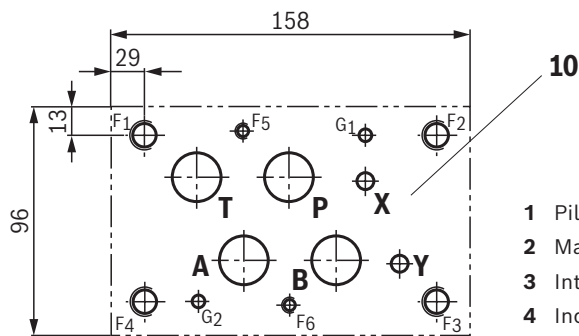
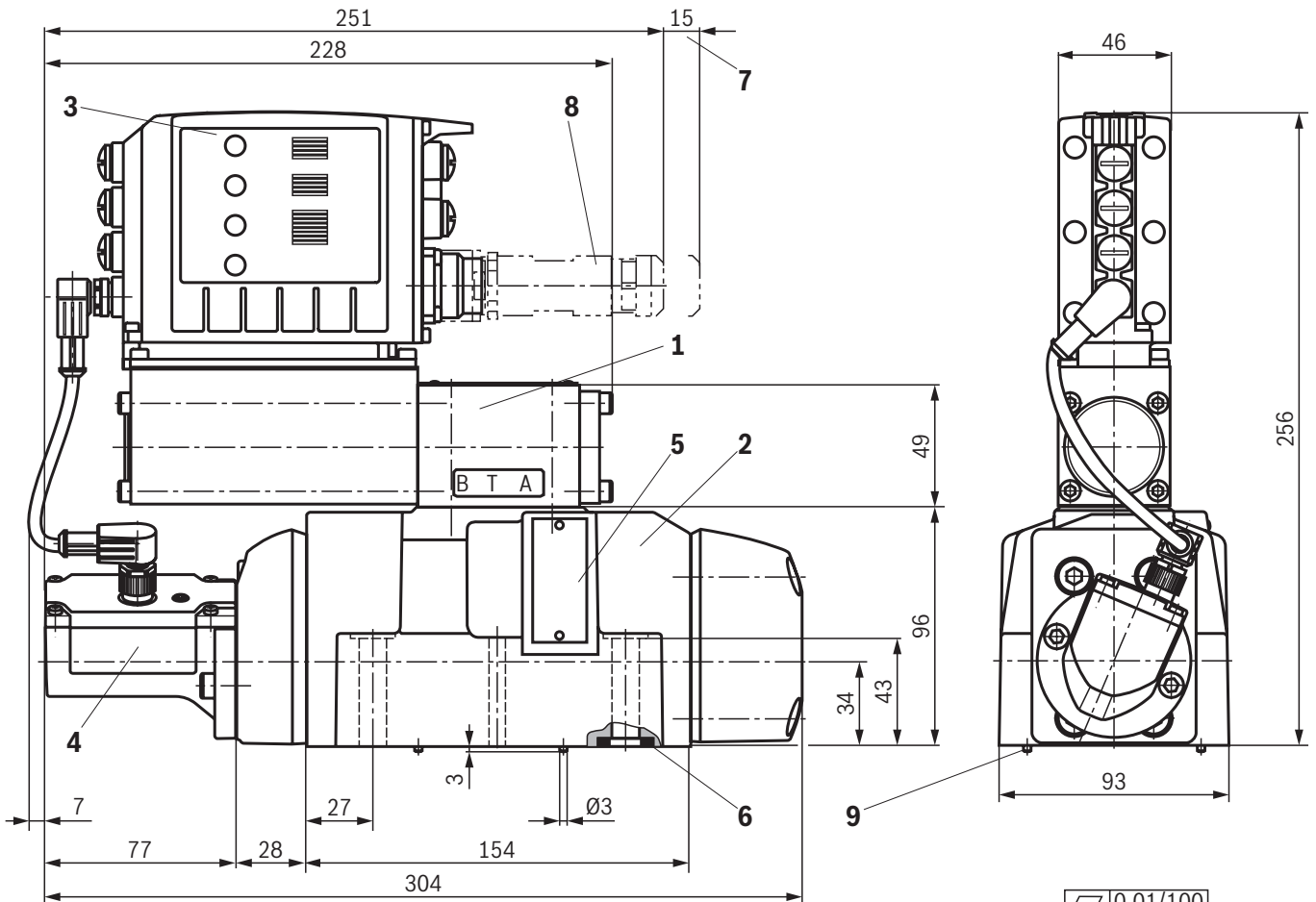

Required surface quality of the valve contact surface

- 1 Pilot control valve
- 2 Main valve
- 3 Integrated electronics (OBE)
- 4 Inductive position transducer (main valve)
- 5 Name plate
- 6 Identical seal rings for ports P, A, B, T
Identical seal rings for ports X, Y
- 7 Space required for removing the mating connector
- 8 Mating connectors, separate order, see page 42 and data sheet 08006.
- 9 Positioning pin
- 10 Machined valve contact surface, porting pattern according to ISO 4401-07-07-0-05
Deviating from the standard: Ports P, A, B, T – $\varnothing 20$ mm
Minimum screw-in depth:
 - ▶ Ferrous metal: $1.5 \times \varnothing$
 - ▶ Non-ferrous metal: $2.0 \times \varnothing$

Valve mounting screws and subplates, see page 41.

Notice:

The dimensions are nominal dimensions which are subject to tolerances.

Dimensions: Size 25
(dimensions in mm)

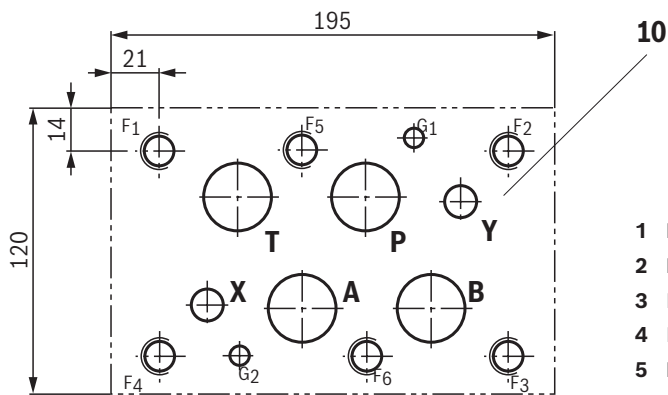
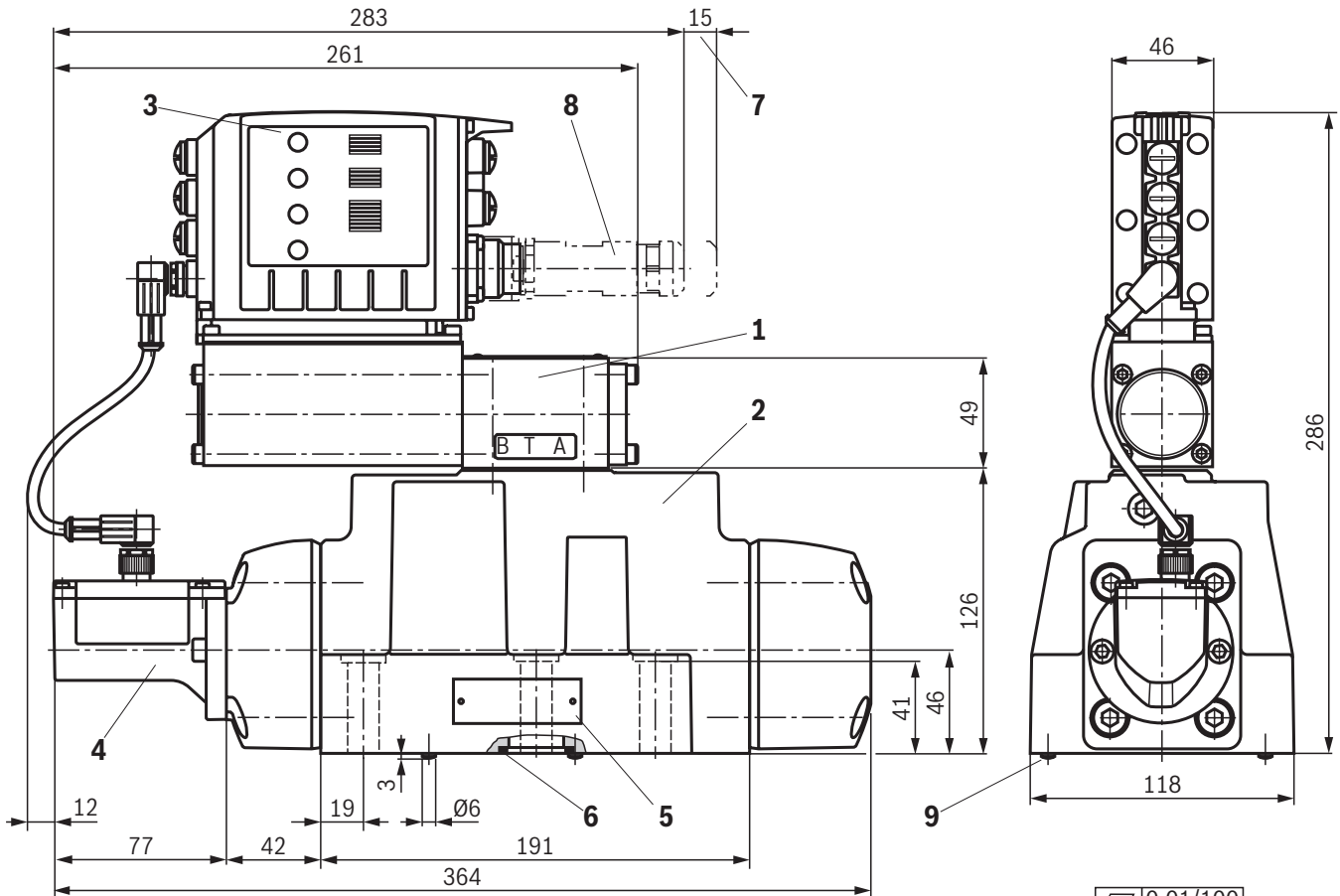

Required surface quality of the valve contact surface

- 1 Pilot control valve
- 2 Main valve
- 3 Integrated electronics (OBE)
- 4 Inductive position transducer (main valve)
- 5 Name plate
- 6 Identical seal rings for ports P, A, B, T
Identical seal rings for ports X, Y
- 7 Space required for removing the mating connector
- 8 Mating connectors, separate order, see page 42 and data sheet 08006.
- 9 Positioning pin
- 10 Machined valve contact surface, porting pattern according to ISO 4401-08-08-0-05
Deviating from the standard:
 - ▶ Ports X, Y – Ø14 mm
 - Minimum screw-in depth:
 - ▶ Ferrous metal: 1.5 x Ø
 - ▶ Non-ferrous metal: 2.0 x Ø

Valve mounting screws and subplates, see page 41.

Notice:

The dimensions are nominal dimensions which are subject to tolerances.

Dimensions: Size 27
(dimensions in mm)

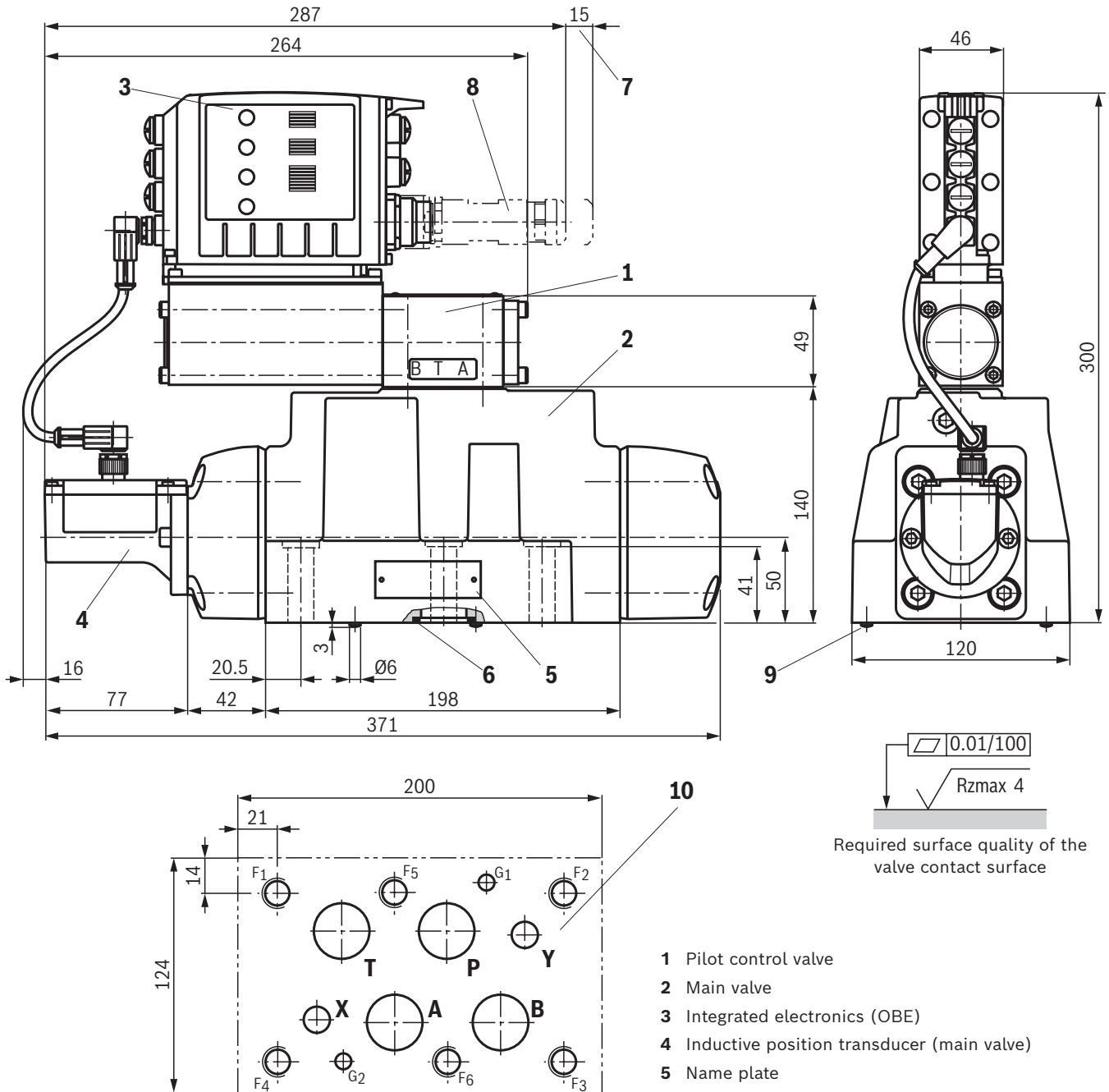

- 1 Pilot control valve
- 2 Main valve
- 3 Integrated electronics (OBE)
- 4 Inductive position transducer (main valve)
- 5 Name plate
- 6 Identical seal rings for ports P, A, B, T
Identical seal rings for ports X, Y
- 7 Space required for removing the mating connector
- 8 Mating connectors, separate order, see page 42 and data sheet 08006.
- 9 Positioning pin
- 10 Machined valve contact surface, porting pattern according to ISO 4401-08-08-0-05
Deviating from the standard:
 - ▶ Ports P, A, B, T – $\varnothing 32$ mm
 - Minimum screw-in depth:
 - ▶ Ferrous metal: $1.5 \times \varnothing$
 - ▶ Non-ferrous metal: $2.0 \times \varnothing$

Valve mounting screws and subplates, see page 41.

Notice:

The dimensions are nominal dimensions which are subject to tolerances.

Dimensions: Size 35
(dimensions in mm)

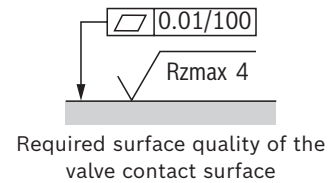
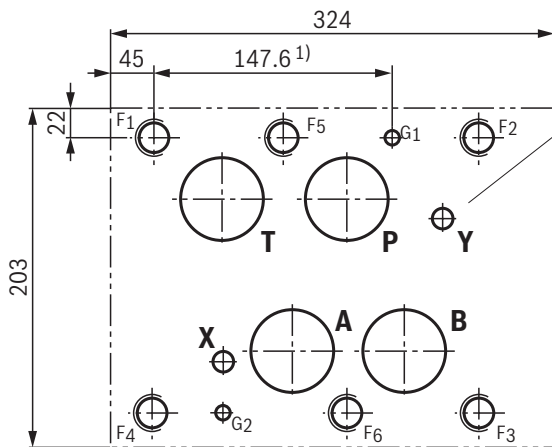
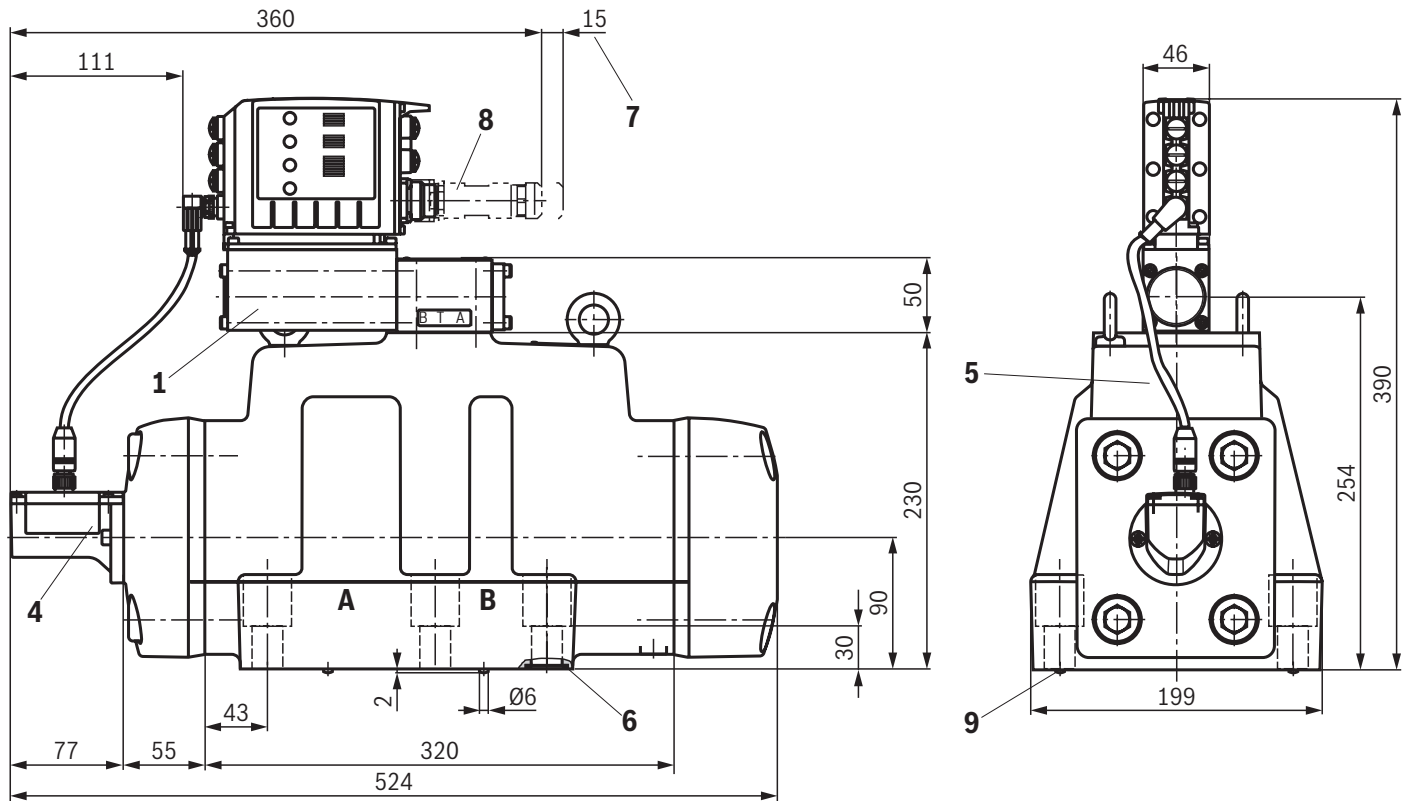

- 1 Pilot control valve
- 2 Main valve
- 3 Integrated electronics (OBE)
- 4 Inductive position transducer (main valve)
- 5 Name plate
- 6 Identical seal rings for ports P, A, B, T
Identical seal rings for ports X, Y
- 7 Space required for removing the mating connector
- 8 Mating connectors, separate order, see page 42 and data sheet 08006.
- 9 Positioning pin
- 10 Machined valve contact surface, porting pattern according to ISO 4401-10-09-0-05
Deviating from the standard: Ports P, A, B, T – Ø50 mm
1) Position G1 according to DIN 24340 Form A

Valve mounting screws and subplates, see page 41.

Notice:

The dimensions are nominal dimensions which are subject to tolerances.

Dimensions

Valve mounting screws (separate order)

Size	Quantity	Hexagon socket head cap screws	Material number
10	4	ISO 4762 - M6 x 45 - 10.9-CM-Fe-ZnNi-5-Cn-T0-H-B Friction coefficient $\mu_{\text{total}} = 0.09 \dots 0.14$; tightening torque $M_A = 13.5 \text{ Nm} \pm 10\%$	R913043777
	or		
	4	ISO 4762 - M6 x 45 - 10.9 Friction coefficient $\mu_{\text{total}} = 0.12 \dots 0.17$; tightening torque $M_A = 15.5 \text{ Nm} \pm 10\%$	Not included in the Rexroth delivery range
	or		
	4	ASME B18.3 - 1/4-20 UNC x 1 3/4" - ASTM-A574 Tightening torque $M_A = 15 \text{ Nm} [11 \text{ ft-lbs}] \pm 10\%$	Not included in the Rexroth delivery range
16	2	ISO 4762 - M6 x 60 - 10.9-CM-Fe-ZnNi-5-Cn-T0-H-B Friction coefficient $\mu_{\text{total}} = 0.09 \dots 0.14$; tightening torque $M_A = 12.2 \text{ Nm} \pm 10\%$	R913043410
	4	ISO 4762 - M10 x 60 - 10.9-fZn/nc/480h/C Friction coefficient $\mu_{\text{total}} = 0.09 \dots 0.14$; tightening torque $M_A = 58 \text{ Nm} \pm 20\%$	R913014770
	or		
	2	ISO 4762 - M6 x 60 - 10.9 Friction coefficient $\mu_{\text{total}} = 0.12 \dots 0.17$; tightening torque $M_A = 15.5 \text{ Nm} \pm 10\%$	Not included in the Rexroth delivery range
	4	ISO 4762 - M10 x 60 - 10.9 Friction coefficient $\mu_{\text{total}} = 0.12 \dots 0.17$; tightening torque $M_A = 75 \text{ Nm} \pm 10\%$	
	or		
2	ASME B18.3 - 1/4-20 UNC x 2 1/4" - ASTM-A574 Tightening torque $M_A = 15 \text{ Nm} [11 \text{ ft-lbs}] \pm 10\%$	Not included in the Rexroth delivery range	
4	ASME B18.3 - 3/8-16 UNC x 2 1/4" - ASTM-A574 Tightening torque $M_A = 60 \text{ Nm} [44 \text{ ft-lbs}] \pm 10\%$		
25, 27	6	ISO 4762 - M12 x 60 - 10.9-fZn/nc/480h/C Friction coefficient $\mu_{\text{total}} = 0.09 \dots 0.14$; tightening torque $M_A = 100 \text{ Nm} \pm 20\%$	R913015613
	or		
	6	ISO 4762 - M12 x 60 Friction coefficient $\mu_{\text{total}} = 0.12 \dots 0.17$; tightening torque $M_A = 100 \text{ Nm} \pm 10\%$	Not included in the Rexroth delivery range
	or		
	6	ASME B18.3 - 1/2-13 UNC x 2 1/4" - ASTM-A574 Tightening torque $M_A = 110 \text{ Nm} [81 \text{ ft-lbs}] \pm 10\%$	Not included in the Rexroth delivery range
35	6	ISO 4762 - M20 x 60 - 10.9-fZn/nc/480h/C Friction coefficient $\mu_{\text{total}} = 0.09 \dots 0.14$; tightening torque $M_A = 465 \text{ Nm} \pm 20\%$	R913014726
	or		
	6	ISO 4762 - M20 x 60 - 10.9 Friction coefficient $\mu_{\text{total}} = 0.12 \dots 0.17$; tightening torque $M_A = 610 \text{ Nm} \pm 10\%$	Not included in the Rexroth delivery range
	or		
	6	ASME B18.3 - 3/4-10 UNC x 2 1/4" - ASTM-A574 Tightening torque $M_A = 395 \text{ Nm} [291 \text{ ft-lbs}] \pm 10\%$	Not included in the Rexroth delivery range

Notice:

- ▶ The tightening torque of the hexagon socket head cap screws refers to the maximum operating pressure.
- ▶ Only the valve mounting screws listed here may be used (for size 16, a minimum screw length of 55 mm is admissible, as well).
- ▶ Prior to assembly, check the existing mounting bore on the block for sufficient screw-in depth.

Subplates (separate order) with porting pattern according to ISO 4401, see data sheet 45100.

Accessories (separate order)**Mating connectors and cable sets**

Port	Designation	Version	Short designation	Material number	Data sheet
XH2	Mating connector; for valves with round connector, 11-pole + PE	Metal, shielded	12PN11 ... EMC	R901268000	08006
		Plastic, two cable outlets	12PN11...2XD8	R900884671	
	Cable sets; for valves with round connector, 11-pole + PE	Metal, shielded, 5 m	12PN11REFS EMV...BG	R901272854	
		Metal, shielded, 20 m		R901272852	
		Plastic, shielded, 5 m	12PN11REFF 2X...	R900032356	
Plastic, shielded, 20 m	R900860399				
X7E1, X7E2	Cable set; shielded, 4-pole, D coding	Straight connector M12, on straight connector M12, line cross-section 0.25 mm ² , CAT 5e, length freely selectable (= xx.x)	–	R911172111 ¹⁾	–
	Cable set; shielded, 4-pole	Straight connector M12, on straight connector RJ45, line cross-section 0.25 mm ² , CAT 5e, length freely selectable (= xx.x)	–	R911172135 ²⁾	–
X2M1, X2M2	Cable set; shielded, 5-pole, for connecting Rexroth pressure sensors, type HM20, A coding	PUR/PVC, straight connector M12, on straight socket M12, line cross-section 0.34 mm ² , 0.6 m	–	R901111709	–
		PUR/PVC, straight connector M12, on straight socket M12, line cross-section 0.34 mm ² , 1.0 m	–	R901111712	–
		PUR/PVC, straight connector M12, on straight socket M12, line cross-section 0.34 mm ² , 2.0 m	–	R901111713	–
	Cable set; shielded, 5-pole, A coding	Straight connector M12, on free line end, line cross-section 0.34 mm ² , 1.5 m	–	R901111752	–
		Straight connector M12, on free line end, line cross-section 0.34 mm ² , 3.0 m	–	R901111754	–
		Straight connector M12, on free line end, line cross-section 0.34 mm ² , 5.0 m	–	R901111756	–
		Straight connector M12, on free line end, line cross-section 0.34 mm ² , 10.0 m	–	R913005147	–
	Plug-in connector; 5-pole, M12 x 1, pins, A coding	Metal (cable diameter 4 ... 6 mm)	–	R901075542	–
	X8M	Cable set; shielded, 8-pole, A coding (only SSI, 1Vpp) ³⁾	Straight connector M12, on free line end, line cross-section 0.25 mm ² , 10 m	–	R913002641

1) Additional indication of type designation RKB0040/xx.x

2) Additional indication of type designation RKB0044/xx.x

3) Recommendation: Sensor manufacturer Heidenhain when using an EnDat 2.2 sensor.

**Notice:**

- ▶ Tighten the M12 connector with a manual torque wrench by 1 Nm.
- ▶ Self-locking M12 cables must be used.
- ▶ It must be ensured that cables are secured without radial forces.
- ▶ All cables connected to XH2, X7E1 and X7E2 must be bundled in a wire harness after 20 cm at the latest. The wire harness must be fixed after further 20 ... 30 cm. Make sure that there is no relative motion between the fixation and the valve.
- ▶ Before the fixation point, there must not be any cable loops.
- ▶ In general, the information on installation provided by the cable manufacturers must be observed.
- ▶ Respectively, the cables of X2M1, X2M2 and X8M, if used, are also fixed as described above.
- ▶ For further information, see operating instructions 29391-B

Accessories (separate order)

Protective cap

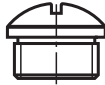
Protective cap M12	Version	Material number
		R901075563

Parameterization

The following is required for the parameterization with PC		Material number/download
Commissioning software	IndraWorks, Indraworks D, Indraworks DS	www.boschrexroth.com/IAC
Connection cable, 3 m	Shielded, M12 on RJ45, length can be freely selected (= xx.x)	R911172135 (additional indication of type designation RKB0044/xx.x)

Representation of the axis controller in the system network

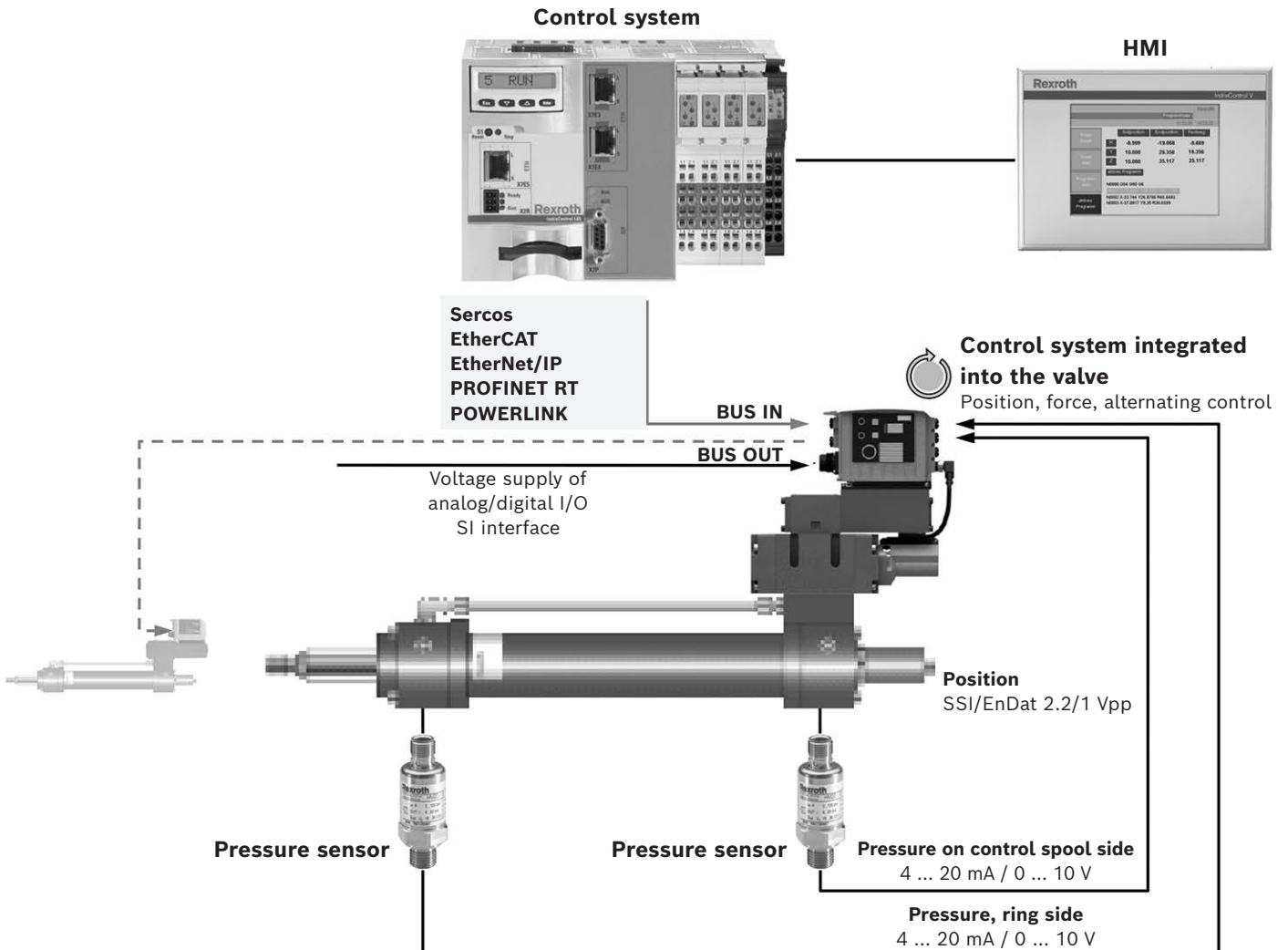

Project planning information

- ▶ The supply voltage must be permanently connected; otherwise, bus communication is not possible.
- ▶ If electro-magnetic interference is to be expected, take appropriate measures for ensuring the function (depending on the application, e.g. shielding, filtration).
- ▶ The devices have been tested in the plant and are supplied with default settings.
- ▶ Only complete devices can be repaired. Repaired devices are returned with default settings. User-specific settings will not be applied. The machine end-user will have to retransfer the corresponding user parameters.
- ▶ When replacing component series 3X with 4X, only the valve mounting screws listed in the data sheet may be used. Prior to assembly, check the existing mounting bore on the block for sufficient screw-in depth.
- ▶ The maximum operating pressure of 350 bar at port T is possible with size 35 from component series 43. For component series ≤ 42 , the valve may be operated up to a maximum of 250 bar.
- ▶ Maximum operating pressure of 350 bar at port T only with double flow (supply via ports P and T, discharge via ports A and B; the supply pressure must be kept constant, load pressure in the discharge can be pulsating) without changing the direction of flow.
- ▶ Can be used without restriction up to a maximum operating pressure of 250 bar at port T.

Further information

- | | |
|---|--|
| ▶ Directional control valve with integrated digital axis controller (IAC-Multi-Ethernet, component series 2X) | Data sheet 29391 and 29391-B |
| ▶ Operation fieldbus electronics (xx = software version): | |
| – Functional description Rexroth HydraulicDrive HDx-20 | – 30338-FK |
| – Parameter description Rexroth HydraulicDrive HDS-16, HDx-17 ... HDx-20 | – 30330-PA |
| – Description of diagnosis Rexroth HydraulicDrive HDS-16, HDx-17 ... HDx-20 | – 30330-WA |
| ▶ Subplates | Data sheet 45100 |
| ▶ Hydraulic fluids on mineral oil basis | Data sheet 90220 |
| ▶ Environmentally compatible hydraulic fluids | Data sheet 90221 |
| ▶ Flame-resistant, water-free hydraulic fluids | Data sheet 90222 |
| ▶ Flame-resistant hydraulic fluids – containing water (HFAE, HFAS, HFB, HFC) | Data sheet 90223 |
| ▶ Hexagon socket head cap screw, metric/UNC | Data sheet 08936 |
| ▶ Hydraulic valves for industrial applications | Data sheet 07600-B |
| ▶ General product information on hydraulic products | Data sheet 07008 |
| ▶ Installation, commissioning and maintenance of servo valves and high-response valves | Data sheet 07700 |
| ▶ Assembly, commissioning and maintenance of hydraulic systems | Data sheet 07900 |
| ▶ CE Declaration of Conformity | Upon request |
| ▶ Commissioning software and documentation on the Internet | www.boschrexroth.com/IAC |
| ▶ Information on available spares | www.boschrexroth.com/spc |

Bosch Rexroth AG
 Industrial Hydraulics
 Zum Eisengießer 1
 97816 Lohr am Main, Germany
 Phone +49 (0) 93 52/ 40 30 20
my.support@boschrexroth.com
www.boschrexroth.com

© All rights reserved to Bosch Rexroth AG, also regarding any disposal, exploitation, reproduction, editing, distribution, as well as in the event of applications for industrial property rights.
 The data specified above only serve to describe the product. No statements concerning a certain condition or suitability for a certain application can be derived from our information. The information given does not release the user from the obligation of own judgment and verification.
 It must be remembered that our products are subject to a natural process of wear and aging.